

price \$8.00



VS-99 SERIES

INSTRUCTION MANUAL
AND
ILLUSTRATED PARTS BREAKDOWN
FOR SERIES II ELECTRONICS



Lektro-Vend Corp. 911 W. Sullivan Road • Aurora, IL 60506 • Phone (708) 896-8555

TABLE OF CONTENTS

	PAGE
WARRANTY	2
SPECIFICATIONS	3
SCHEMATIC	4
CAPACITIES	5
UNPACKING	6
INSTALLATION & SET UP	6
1. LEVELING	6
2. MAIN POWER CORD	6
3. LOADING SNACK SHELVES	6
4. LOADING CANDY SHELVES	6
5. PRODUCT GUIDES	6
6. SPIRAL REMOVAL	6
7. PRODUCT PUSHER	6
8. PRODUCT SPACERS	6
9. TRAY ARRANGEMENT	7
10. TRAY REMOVAL	7
11. INSTALL PRICE TABS	8
12. LOADING THE GUM & MINT	8
13. ELECTRONIC CONTROLLER MODES	8
14. PRICE SETTING	8
15. COPY PRICE SETTING	8
16. FREE VENDING	9
17. FORCED VEND OFF	9
18. FORCED VEND ON	9
19. NUMBER OF MOTORS CONFIGURED	9
COMPONENTS	
1. POWER SUPPLY	9
2. DOOR SWITCH	9
3. CHANGERS	10
4. ELECTRONIC CONTROLLER	10
5. SELECTION PANEL	11
6. VEND MOTORS	12
7. LED DISPLAY	12
8. LIGHTING	12
9. BILL VALIDATORS	12
10. CASH COUNTER	12
11. REMOVAL OF THE GUM & MINT	12
CLEANING	13
TROUBLE SHOOTING	14
PARTS LIST	
1. MACHINE FINAL ASSEMBLY	15-17
2. TOP TRAY ASSEMBLY COMPLETE	18-19
3. WIDE COLUMN TRAY ASSEMBLY COMPLETE	20-21
4. NARROW COLUMN TRAY ASSEMBLY COMPLETE	22-23
5. MINT UNIT FINAL ASSEMBLY	24-25
6. DOOR ASSEMBLY	26-30
7. DELIVERY TRAY ASSEMBLY	31-32
8. JUNCTION BOX ASSEMBLY	33
9. INSTALLATION OF MAKA ACCEPTORS	34
10. INSTALLATION OF MARS ACCEPTORS	35
11. SMALL MINT RETAINER KIT	36



WARRANTY

Lektro-Vend Corp. warrants this equipment to the Original Purchaser only, to be free from significant defects in material or workmanship, for a period of twelve months from the date of shipment. The warranty period of twelve months applies to purchased components or to the extent such parts are warranted to Lektro-Vend, whichever is less. This warranty does not include starters, light bulbs, and fuses.

Any defective part, returned within the warranted period, will be repaired or replaced at Lektro-Vend's option. This warranty does not cover the labor of removal or reinstallation associated with such parts. The returned products or parts must be shipped, freight prepaid, to Lektro-Vend. Lektro-Vend will prepay the shipping cost of the returned goods. Any part returned under the terms of this warranty must be accompanied by the Lektro-Vend Parts Return Form, with proper documentation.

The warranty is voided if a defect is caused by improper power supply, abuse of product, accident, alteration, vandalism, improper cleaning, incorrect wiring, improper installation, units repaired or altered, where serial numbers have been altered, or improperly serviced (not in accordance with the instructions given in the Lektro-Vend Service Manual). The warranty applies only to our products which are used in the United States of America, and is in lieu of all warranties expressed or implied.

Lektro-Vend reserves the right to make any changes or improvements in its product without notice and without obligation, and without being required to make corresponding changes or improvements in products theretofore or sold.

SPECIFICATIONS

VENDING COMPARTMENT SIZES

Chips 7-3/8" High, 5-1/2" Wide
Candy 7-3/8" High, 2-3/4" Wide

CONTROL - ELECTRONIC

ELECTRICAL - 115 VAC 60/50 HZ

CAPACITY & SPACING PER SPIRAL

10 Products 2"/EA
12 Products 1-3/4"/EA
14 Products 1-1/2"/EA
18 Products 1-3/16"/EA
22 Products 1"/EA
27 Products 13/16"/EA

MACHINE SPECIFICATIONS

MODEL	SHIP WT.	WIDTH	HEIGHT	DEPTH
A	490#	29"	72"	35"
B	560#	34-1/2"	72"	35"
C	630#	40"	72"	35"

WARNING:
 UNPLUG MACHINE OR REMOVE FUSE BEFORE DISCONNECTING OR CONNECTING ANY ELECTRICAL PLUG. THIS WILL PREVENT POSSIBLE DAMAGE TO ELECTRONICS.

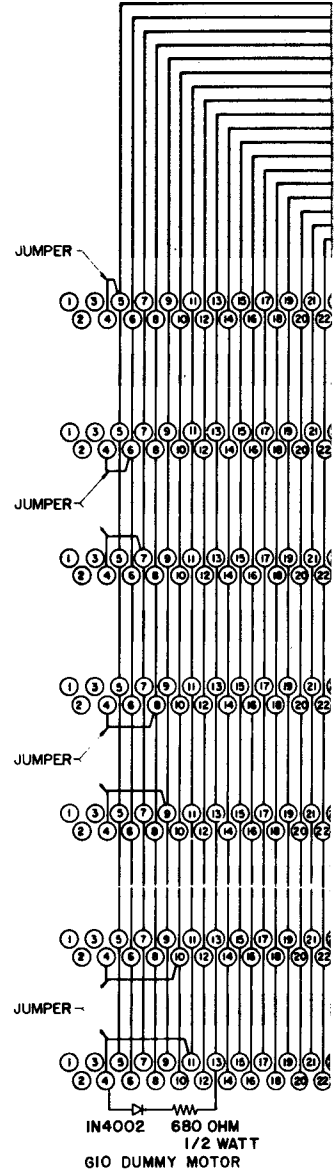
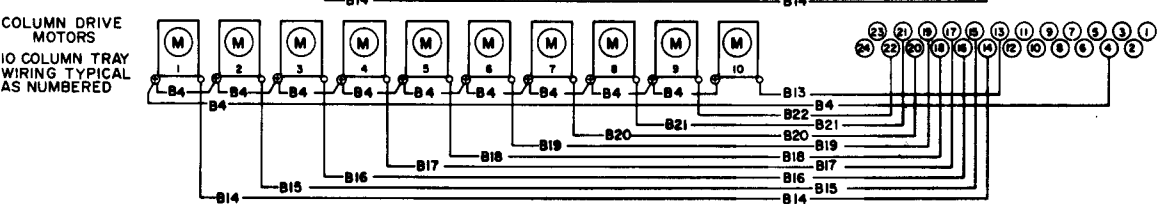
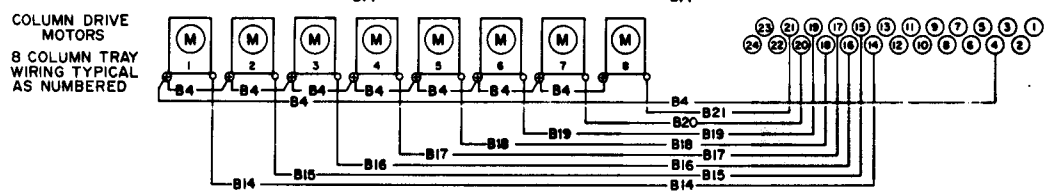
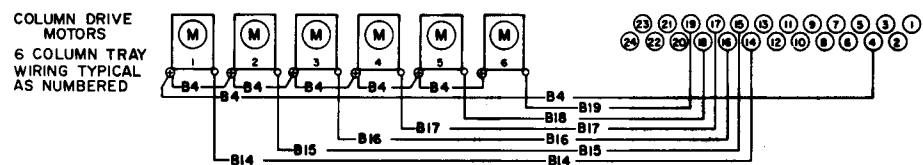
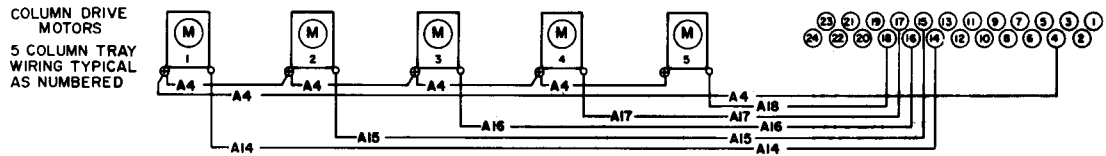
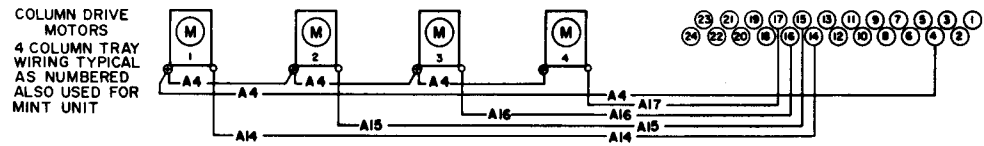
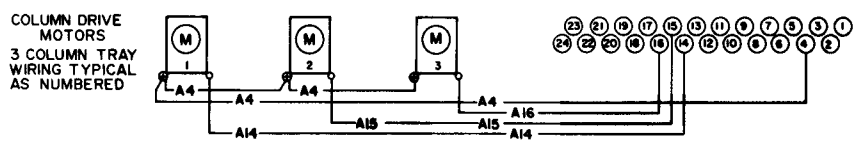

NOTE:
 EXHAUST FAN ASSEMBLY (K-102) MUST BE ATTACHED TO THE 117 V.A.C. SIDE OF THE TRANSFORMER (KIT L1) TO THE TRANSFORMER SIDE OF FUSE (BLACK WIRE) AND KIT L2 TO THE BLACK AND RED WIRE.

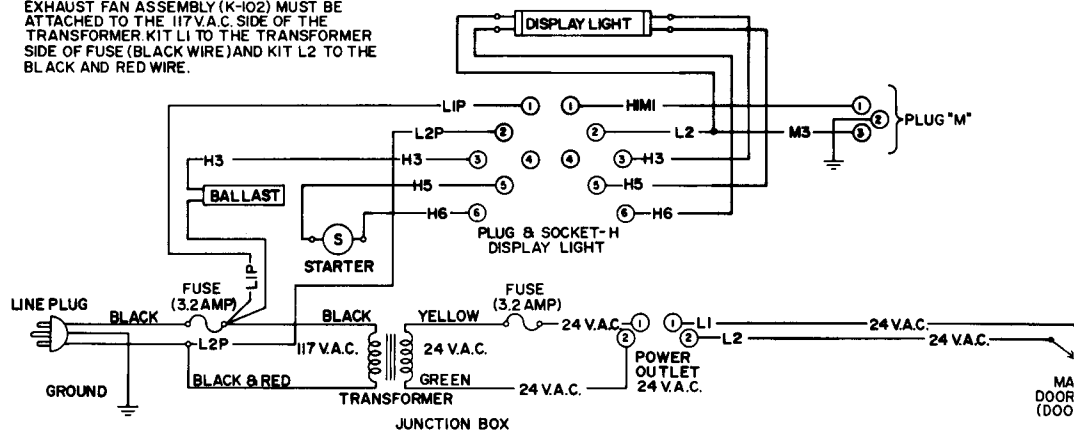
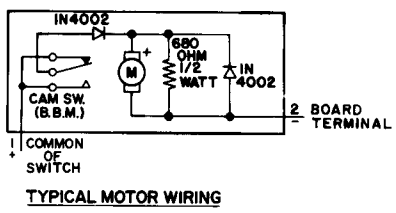

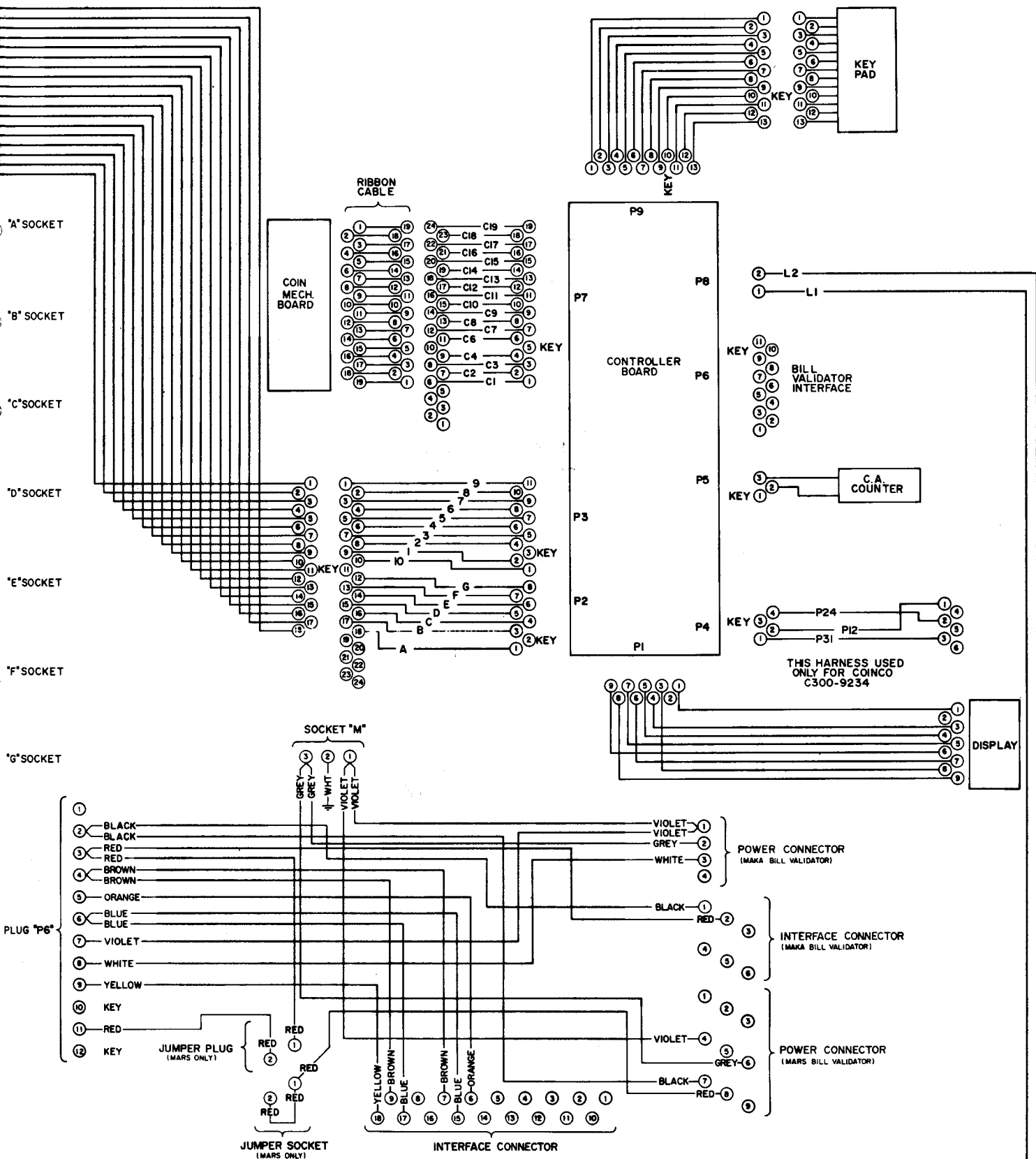

CAPACITIES

Unless otherwise specified the machine will be shipped with the spirals shown below:

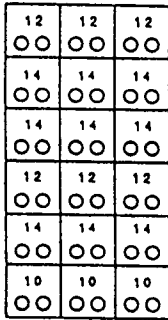

Model A18E
18 Selections
Shelf Capacity 228

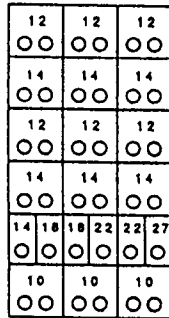

Model A21E
21 Selections
Shelf Capacity 307

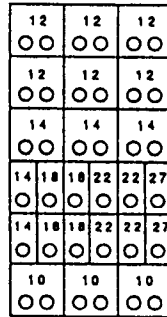

Model A24E
24 Selections
Shelf Capacity 386



Model A27E
27 Selections
Shelf Capacity 471

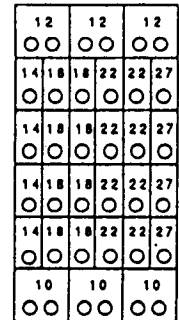

Model A30E
30 Selections
Shelf Capacity 550

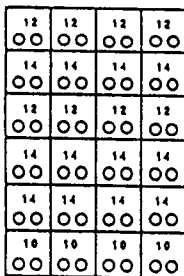

Model B24E
24 Selections
Shelf Capacity 304

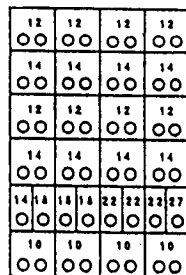

Model B28E
28 Selections
Shelf Capacity 409

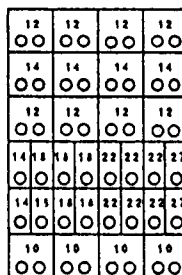

Model B32E
32 Selections
Shelf Capacity 514

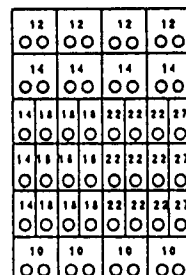

Model B36E
36 Selections
Shelf Capacity 627

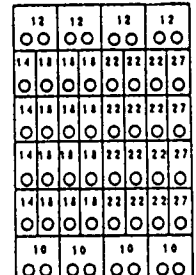

Model B40E
40 Selections
Shelf Capacity 732

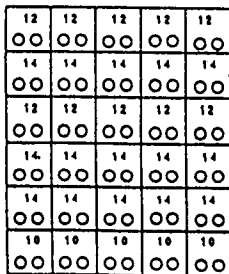

Model C30E
30 Selections
Shelf Capacity 380

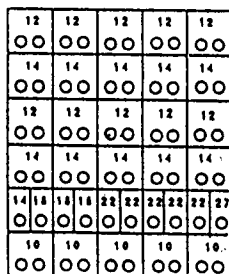

Model C35E
35 Selections
Shelf Capacity 515

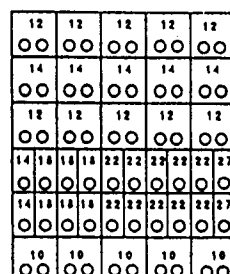

Model C40E
40 Selections
Shelf Capacity 650

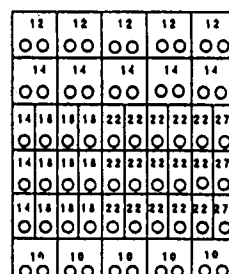

Model C45E
45 Selections
Shelf Capacity 795

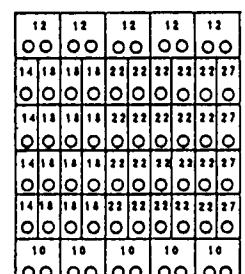

Model C50E
50 Selections
Shelf Capacity 930



UNPACKING

Your Lektro-Vend VS-99 series vendors is packed so that a minimum amount of time is required for installation.

1. Cut the bands at the top and bottom of the carton.
2. Remove the top cap.
3. Lift the tube up until it is clear of the vendor. If there is insufficient head room, the carton can be cut. Exercise care to not mar the finish of the machine.
4. Lift the machine from the shipping pallet. Lektro-Vend machines should be hand trucked from the back or fork lifted from the side.
5. Thoroughly inspect the carton and the machine for physical damage. Report any damage to the carrier and follow their instructions.

INSTALLATION & SET UP

Leveling: Proper leveling is important for the vendor to operate correctly.

Leveling is accomplished by adjusting the screw levelers in each of the legs.

Main Power Cord: The VS-99 vendor is equipped with a third wire ground power cord. It should be plugged into a 115 volt 60 HZ grounded outlet only.

Loading Snack Shelves: The product trays in the VS-99 vendor have no locking latch so they can be pulled straight forward until the rear stop is engaged. The tray can then be tilted down for loading.

NOTE: Only one product shelf should be in the loading position at a time.

When loading the product make sure that the top of the bag will clear the rail member above it. Never force product between the spirals, it should fit freely. Make sure the bottom flaps on the bags are not wedged under the spiral.

Loading Candy Shelf: The candy shelves are loaded similar to the snack shelves. The product should not be forced between the spirals and should fit freely. Spiral removal is the same as the snack shelf spirals.

Product Guides: Your VS-99 is designed so spring type product guides can be used to obtain the proper alignment of chip type products during the vend. A supply of these assemblies are located in the bottom of the vendor. To install, position the product guide assembly under the appropriate rack cross member and align the holes. Now bolt into place with the provided hardware.

The guides are locked into position by pressing the swinging portion of the product guide assembly up, till the "Velcro" latch is engaged. Reverse this procedure to move the guides out of the way.

Spiral Removal: VS-99 vendors produced after October 5, 1987 are equipped with a quick spiral removal system. This can be visually seen by the absence of the spiral retention plate mounted on the hub. To remove the spiral, grasp it near the rear and lift up, then pull forward. To replace the spiral, align properly with the hub and press into place with a flat bladed screwdriver.

The whole hub and spiral assembly can be removed by removing the "E" ring retainer.

Product Pushers: Your VS-99 vendor is supplied with enough product pushers for each spiral in the machine. They are easily installed by snapping them on the end of the spiral. (As shown in figure 1) It is important that the tip of the product pusher reach or extend slightly beyond the edge of the tray. This will insure a proper vend.

Product Spacers: Your VS-99 vendor is equipped with a supply of fully adjustable product spacers. They orient narrow product to the left side of the

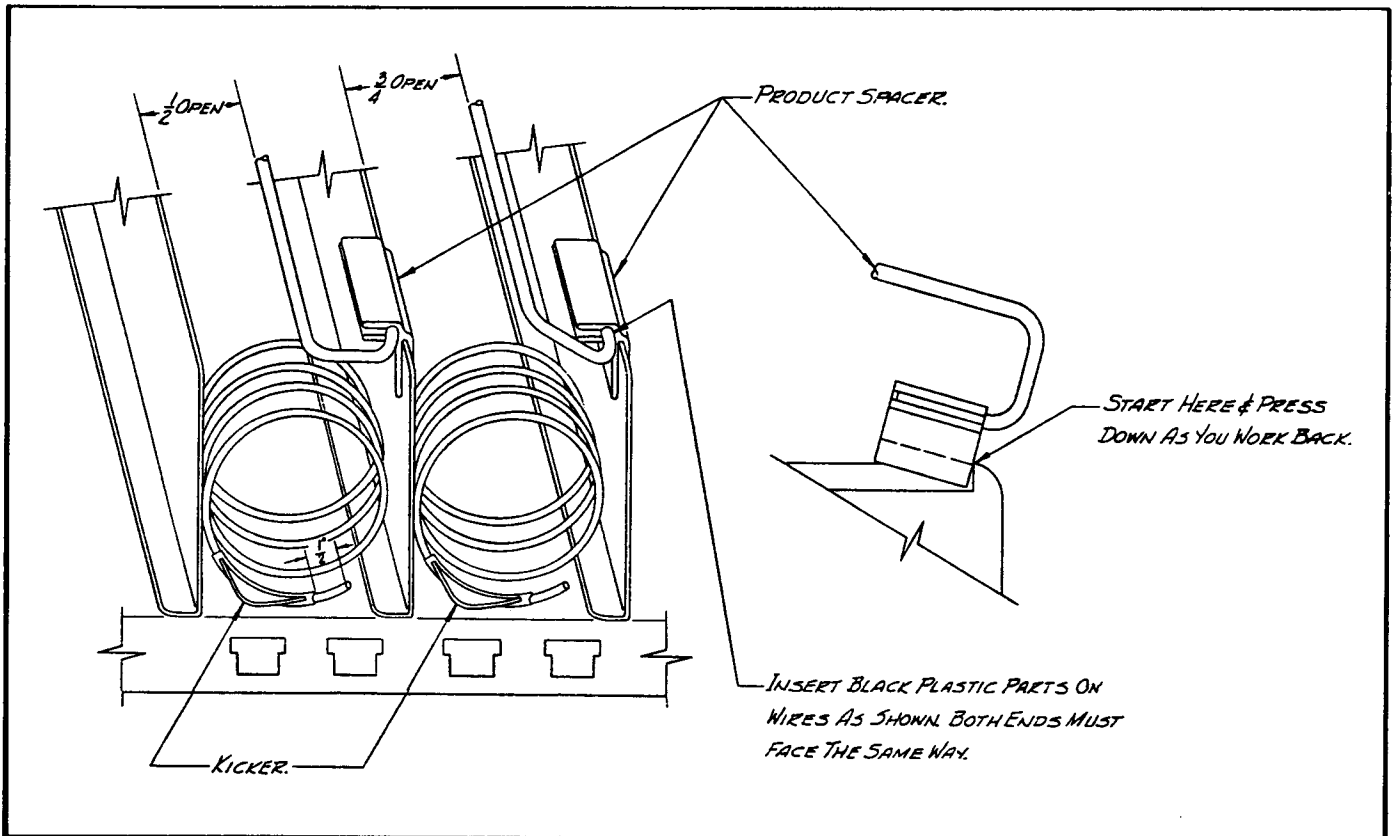

Figure 1

tray compartment. The spacer is mounted as shown in figure 1.

CAUTION: Do not load the adjoining compartment with extra wide product.

Tray Arrangement: The tray arrangement in the VS-99 with the series II electronics, can be altered. Either a candy or snack tray can be used in positions 1 through 6. Be sure that after the trays are re-installed and plugged in, you reprogram the machine by pulling out the door switch and press the mode button. This allows the electronics to reconfigure the machine. Press the mode switch again to go into the vend mode.

Tray Removal: To remove a tray from the machine, start by disconnecting the tray harness. Now pull the tray forward until the rear stop is engaged. While holding the tray front with one hand,

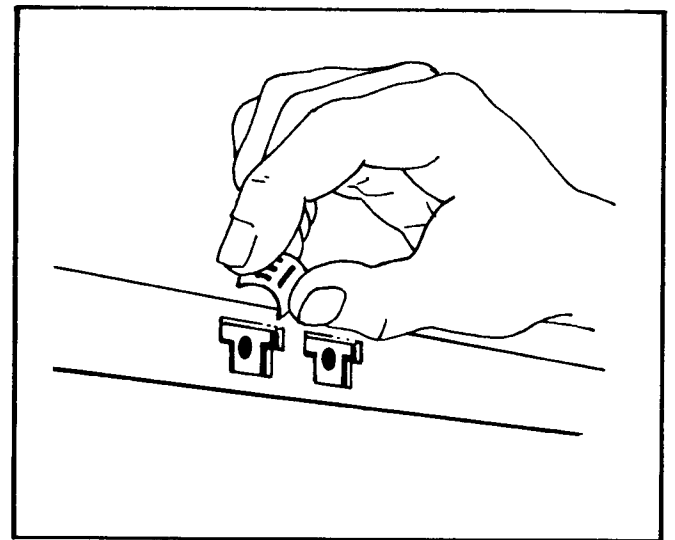

Figure 2

place the other hand on the bottom of the tray. By pushing the tray up while tilting the front up, the tray can now be removed.

NOTE: Be careful not to damage the tray harness.



Install Price Tabs: VS-99 price tabs can be easily installed by simply slipping them into the proper slot in the tray front. (As shown in figure 2)

To check that the pricing is correct, simply press the selection to be checked and the price set in the electronics will be displayed on the LED readout.

Loading The Gum & Mint: The gum and mint is prepared for loading by releasing the slide latch located on the front of the right slide, pulling the unit forward and sliding the cover back. Selections 1 and 3 (from the left) can be adapted for long mints. This is done by grasping the spacer in the selection then pushing back and lifting up. Keep the spacer with the machine so you can convert back to regular size product.

NOTE : The VS-99 gum & mint is equipped with heavy duty ball bearing slides and can be used as a shelf. However, we do not recommend setting any weight over 50 lbs. on it.

Electronic Controller Modes: The electronic controller board is mounted on the inside of the service door in the upper left hand corner. It is protected by a heavy guage steel cover.

When removing or touching the controller board, take extreme care to avoid touching it with or setting it on metal. Also be sure no foreign materials get into the board to short it out.

The controller has two modes:

1. Sales Mode- The sales mode is the primary operating state of the VS-99. In this mode your VS-99 will take money and vend product. The vendor will return to sales mode if button "J" is pushed or if no service related operation is engaged for 25 seconds.

- 2.. Service Mode- The service mode is entered by pushing the mode switch on the controller cover. The "LED" display will provide a readout of faulty or jamed motor locations. Motor locations will alternate in the LED for 25 seconds if no other service functions are entered.

Price Setting: Price setting is done through the selector panel after pressing the mode switch.

1. Press mode switch on the controller housing.
2. Press button number 1.
3. Press the selection to be priced. The LED display will indicate the selection number and then its existing price setting.
4. To increase the price in 5 cent increments, press "H".
5. To decrease the price, press "7".
6. Repeat the above procedure till all the prices are set, then press "J" or wait 25 seconds to return to the sales mode.

Copy Price Setting: To set a number of selections at the same price, use the "Copy Price" feature of the electronics. To use the Copy Price feature, do the following:

1. Set the price of the selection to be copied as described in the Price Setting instructions.
2. Then, press button 5.
3. Now enter the letter and number of each selection to have the same price.
4. To set additional copy prices, repeat steps 1 through 3 as often as needed.

5. To return to the sales mode, press "J" or wait 25 seconds.

Free Vending: Your VS-99 can be "free vended" in 3 ways:

1. Free vend a single selection- First, press the mode button, then button number 1. Now press button number 8 and then the selection number and it will vend without inserting coins. To escape this mode, press 1 or "J" or wait 25 seconds.
2. Free vend a row- First press the mode button, then button number 1. Now press number 9 and the letter of the row to be vended. The selection in the selected row will run in sequence starting with number 1. To escape this mode, press 1 or "J" or wait 25 seconds.
3. Free vend the entire machine- First press the mode button, then button number 1. Now press button number 10 and the machine will run each selection in turn beginning with the last selection in the machine. To stop this feature press and hold button #1 till 3 beeps sound.

Forced Vend OFF: If your VS-99 is equipped with a bill validator, you can elect to use machine as a change maker.

If the bill validator your VS-99 is equipped with does not escrow the bill and you wish to return the full amount in change if the customer does not make a vend, do the following:

1. Press mode button
2. Press number 1
3. Press number 4
4. Press number 1 to return to the service mode then "J" to return to the sales mode.

If the validator in your machine escrows the last bill, it will be returned to the customer in this mode.

Forced Vend ON: If your VS-99 is equipped with a bill validator and you want the customer to make a selection, set the machine as follows:

1. Press mode button
2. Press number 1
3. Press number 3
4. Press number 1 to return to the service mode and then "J" to return to the sales mode.

Number of Motors Configured: To see how many motors are in the vend circuit, press number 2 while in the service mode. The number will be indicated on the LED display.

COMPONENTS

Power Supply: Your VS-99 vendor's power box is located on the bottom of the cabinet. It is equipped with two fuses, both 3.2 AMP standards. The top fuse is for 115 VAC line which powers the cabinet light and bill validators. The bottom fuse is for the 24 VAC line which powers the electronics, LED display and vend motors.

CAUTION: Unplug the machine from the wall outlet when working in this area.

Door Switch: VS-99 vendors produced after October 12, 1987 are equipped with a door activated OFF/ON switch that shuts off the 24 VAC power in the machine.

The switch is mounted on the main shelf support leg and contacts the back of the delivery Compartment for activation.

If you wish to have the power on while the door is open, you must pull the switch plunger out (Pull To Cheat).

CAUTION: The door switch does not shut off the 115 VAC power to the light or bill validator.

Changers: The VS-99 is equipped to take only 24 volt changers. Under no circumstances use any changer rated for other voltages, it will damage the electronic controller.

The VS-99 has a 12 pin plug mounted on the right hand inside cabinet wall. It will accept the following changers:

<u>Manufacturer</u>	<u>Model</u>
Mars	5010
Mars	TRC6010
Coinco	9302L
Maka	usx-002

An 18 pin plug assembly for the Coinco C300-9404-977 or C300E9234 Controller changers is available from the factory.

Electronic Controller: The Microprocessor based control system in your VS-99 vendor is "state -of-the-art" and designed to be user friendly. Figure 3 indicates plug positions on the board for:

1. Vend motors
2. Changer hook up
3. LED Display
4. Validator hook up
5. Coinco 9302L Second harness

NOTE : Do not disconnect board while under power.

Some of the operational characteristics of the VS-99 electronics are:

1. When inserting coins and the highest price set in the machine is reached, the CREMS in the changer will de-energize so no more coins will be accepted.
2. When inserting bills and the highest vend price set in the machine is reached, the validator will not accept any additional.
3. If a vend motor fails to make the motor switch in 2 seconds or unmake in 8 seconds, the controller assumes the motor is jammed. A

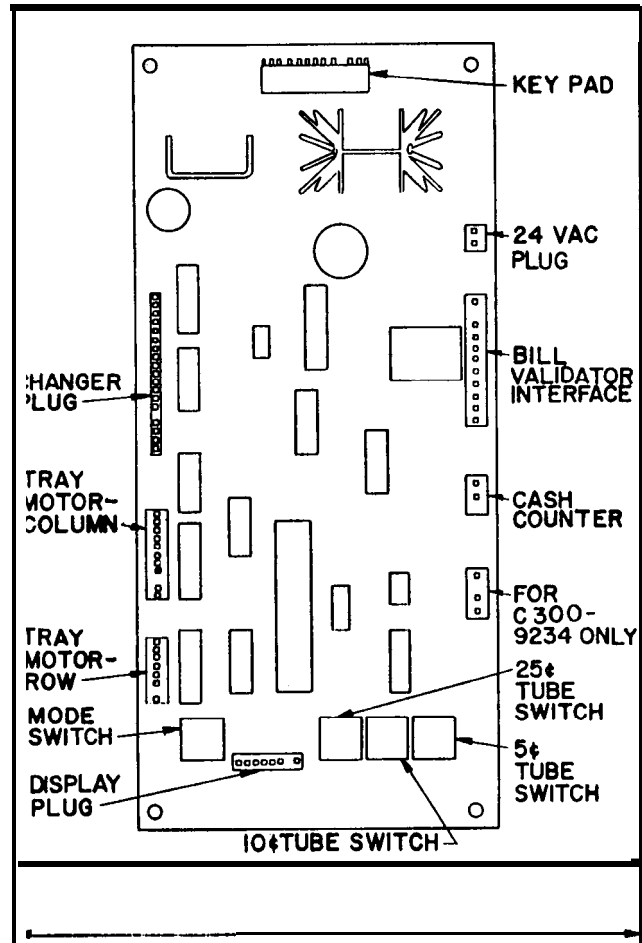

Figure 3

jammed motor does not affect any other selection. The controller will automatically take that selection out of the machine configuration and inform the customer to make an alternate selection. The selection will be reconfigured when it has been free vended and the mode button has been pushed.

4. If the level of coins in the changer is too low, the controller will display "Use correct change" on the LED display and also shut down the bill acceptance feature.

CAUTION: Under no circumstances plug or unplug the changer while the machine is under power. Unpower the machine by removing the cord from the outlet, removing the 24 VAC fuse from the power box or shutting off the door switch.

5. There are four switches mounted on the controller board. They are activated by pushing the buttons on the controller cover. The buttons are:
 - a. Mode Switch - Pressing this will move the machine into the "Service" mode. Pressing "J" or waiting 25 seconds will return the machine to the "Sales" mode.
 - b. 5c, 10c, and 25c tube switches that are used with Mars, Maka or Coinco 9302L changers.
6. When initially going into the "Service" mode the electronics will display on the LED display the following:
 - a. The selection number of faulty or jammed motors.
 - b. The message "24 hours" if the machine has not vended in 24 hours.
7. If a bill validator is used, the machine can be programmed to "forced vend" or a "non-forced vend" system. When "forced vend" is used, the customer must make a vend when a bill is inserted. He cannot use the machine as a change maker.

If the machine is to be used as a change maker, the machine must have a price over \$1.00 in the machine. If you are not selling at this price, we have installed a Dummy Motor on G10. Price this "Motor" over \$1.00. This is so the MARS/ARDAC, Dixie Narco bill validator will stack the first bill going into the validator.

8. When removing the electronics, extreme care should be taken to avoid introducing static electricity to the board. Under no circumstances should the board be placed on metal. To remove the controller, simply remove the electronics cover, unplug the harnesses and gently pull the board off the stand-offs.

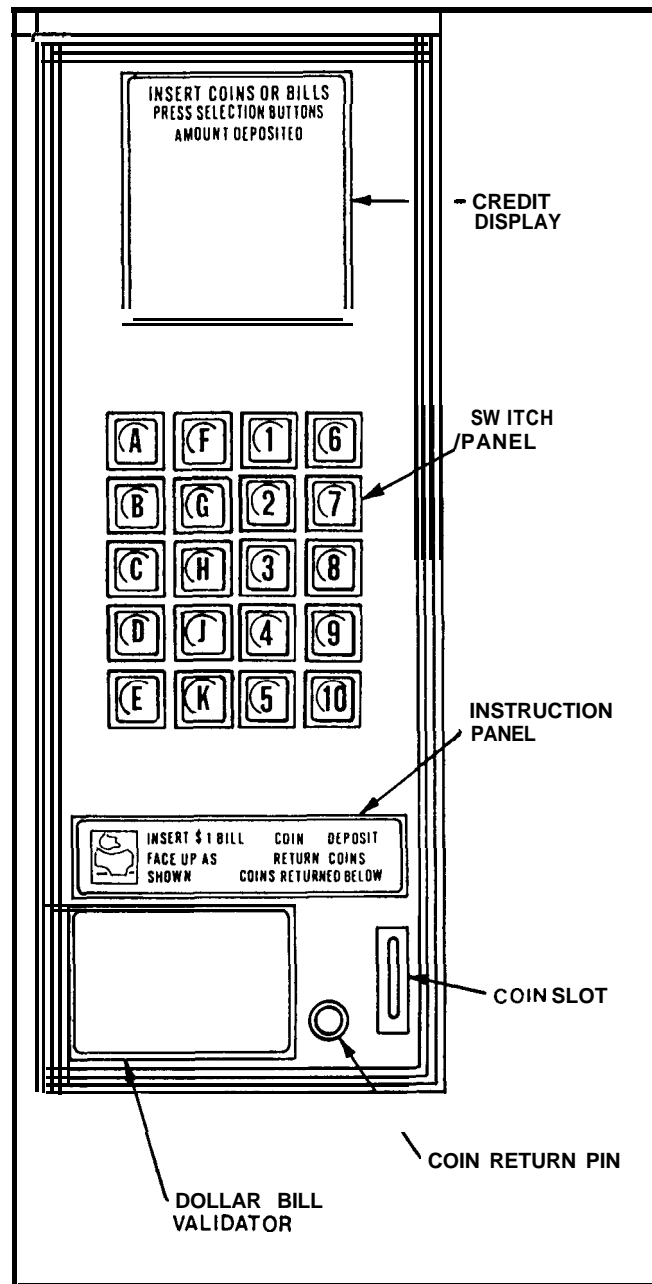

Figure 4

Selection Panel: The selection panel (see figure 4) on your VS-99 incorporates the use of a self enclosed membrane switch system. The panel also provides space for the LED display, coin inlet, coin return lever, instruction glass and bill validator.



Vend Motors: The VS-99 incorporates lightweight 24 VDC vend motors. Do not attempt to home the motor by hand.

LED (Light Emitting Diode) Display:

Your VS-99 is equipped with a scrolling LED customer / service message display. In the vend mode it will display to the customer the following:

1. When no credit is established, the display will flash the word "Price" and then the actual price of the selection pressed.
2. When credit is established, the display will show the word "Credit" for 1 second then the amount of the credit.
3. If there is insufficient credit for the selection pressed, the display will show the word "Price" and then the actual price. In 2 seconds the display will revert back to showing the amount of the credit.
4. When the customer selects a product whose motor is jammed, the display will flash the words "Make Another Selection".
5. When the changers pay-out tubes are too low, the display will show the message "Exact Change Only".

In the service mode, the LED will display various pieces of information depending on the service function being done.

Lighting: The VS-99 uses 115 VAC fluorescent lamp located at the top of the door. The ballast is located in the power box.

Bill Validators: Your VS-99 is equipped to utilize 115 VAC validators manufactured by Maka, Mars and Ardac. A package of brackets, mounting hardware and instruction sheets for mounting all Maka and Mars validators is included in the parts package.

An additional bracket for mounting the Ardac validator is required and is available from the factory upon request.

A universal harness for Maka, Mars and Ardac validators is pre-mounted in the machine. After you have mounted the validator, plug it into the proper plugs on the harness as per the instruction sheet.

The VS-99 will accept the following validators:

1. Maka NB11B (120 bill capacity, accepts \$1 only).
2. Maka NB11B400 (400 bill capacity, accepts \$1 only).
3. Mars 91-30-028-4 (185 bill capacity accepts \$1 & \$5).
4. Mars 91-30-029-4 (400 bill capacity accepts \$1 & \$5).
5. Ardac 1X224-0503 MBA (200 bill capacity, accepts \$1 only).

Cash Counter: The VS-99 incorporates as standard equipment a non-resettable electro-mechanical cash meter. It counts in actual dollars and cents the total net sales of the machine. As an example if a customer puts in \$1.00 and selects a 75c item, the meter will record 75c.

Removal Of The Gum & Mint: To remove the gum & mint unit you must first disconnect the Spring Holder Bracket (figure 5) that is located underneath the tray assembly. Then disconnect the harness. Now you can pull the unit forward until the back latch on the right hand side is engaged. Depress the latch and remove the unit completely.

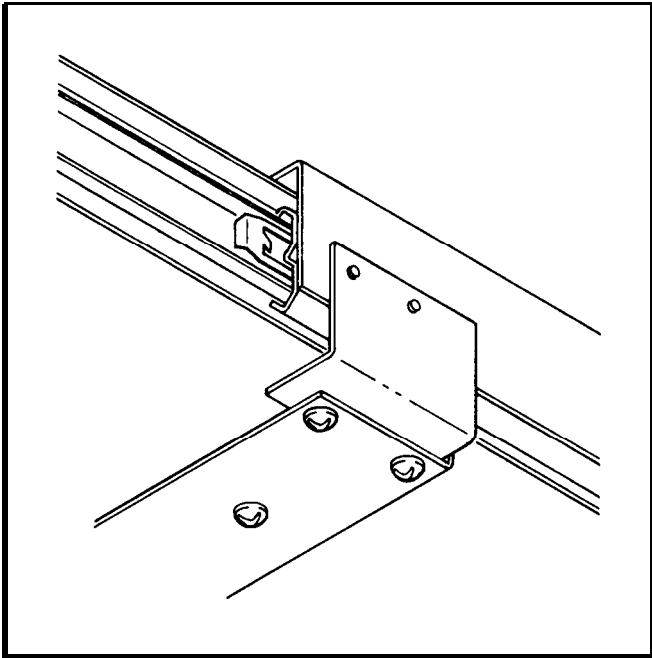

Figure 5

CLEANING:

Periodically the inside of the merchandiser should be cleaned for sanitary and appearance reasons. This should be done as needed. Clean the inside with warm water and mild soap solution. Be sure to rinse afterwards with clean water and wipe all surfaces dry. The trays may be cleaned by lifting up the augers to clean under them. Also clean the base of the machine inside the delivery tray and all other surfaces and parts as necessary. Pay particular attention to all parts that may come in contact with the merchandise being sold. However, do not forget the base of the machine in those hard to get at corners.

NOTE: Never use water around the electronics.

TROUBLE SHOOTING

PROBLEM	CAUSE
Machine will not accept coins.	<ul style="list-style-type: none"> -Unit not plugged in. -24 volt fuse blown. -Incorrect changer used. -Machine has reached highest vend price. -Controller is defective. -Changer defective.
Machine accepts coins but will not vend	<ul style="list-style-type: none"> -Main vend motor harness is loose. -Changer is defective. -Controller is defective.
A selection will not vend.	<ul style="list-style-type: none"> -Loose motor wire. -Defective motor. -Controller is defective. -Selector switch defective. -Vend price has not been reached.
Changer pays out undeserved change.	<ul style="list-style-type: none"> -Defective changer. -Defective controller.
LED Display is blank.	<ul style="list-style-type: none"> -Defective display. -Defective controller. -24 volt fuse blown. -Unit not plugged in. -LED display not connected to the controller.
LED Display does not show credit but is otherwise lit.	<ul style="list-style-type: none"> -Defective changer. -Defective controller.
Coin tubes will not empty but there is 24 V power.	<ul style="list-style-type: none"> -Defective changer. -Defective controller.
LED Display shows "Make another selection" when a selection is pressed.	<ul style="list-style-type: none"> -Jammed motor,
Cannot set prices in the machine.	<ul style="list-style-type: none"> -Defective selector switch. -Defective controller.
Bill validator will not accept bills.	<ul style="list-style-type: none"> -Highest vend price has been reached. -Changer tubes are low.
Accepts bill but does not show credit on the display and will vend.	<ul style="list-style-type: none"> -Defective display.
Accepts bill but does not show credit on the display and will not vend.	<ul style="list-style-type: none"> -Defective validator. -Defective validator harness. -Defective controller.
Machine tries to pay out change but does not have enough power to do so.	<ul style="list-style-type: none"> -Defective changer. -Defective controller,
Changer pays out undeserved change.	<ul style="list-style-type: none"> -Defective changer. -Defective controller.
Machine will not go into service mode or come out of service mode.	<ul style="list-style-type: none"> -Defective switch on the controller.
One motor does not run or half cycles.	<ul style="list-style-type: none"> -Defective motor. -Defective controller.

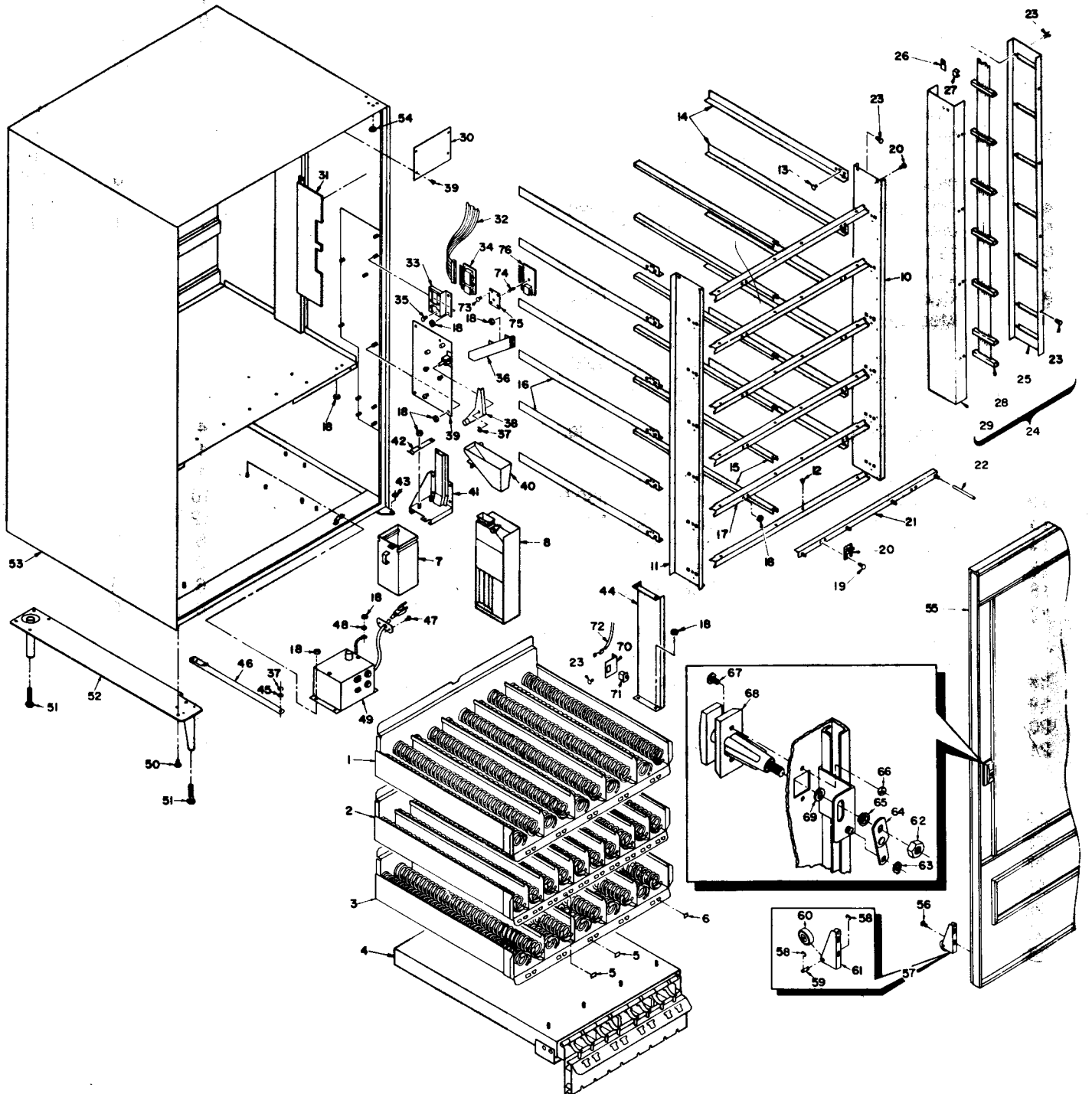

Figure 6 - MACHINE FINAL ASSEMBLY

INDEX NO.	PART NO.	DESCRIPTION	QTY. PER ASSEMBLY MODEL NO.		
			A	B	C
1	099-5041	3 Column Top Tray Assembly	1		
	099-5043	4 Column Top Tray Assembly	0	01	00
	099-5045	5 Column Top Tray Assembly	0	0	1
2	099-5047	6 Column Tray Assembly	0-3	0	0
	099-5048	8 Column Tray Assembly	0	0-3	0
	099-5049	10 Column Tray Assembly	0	0	0-3
3	099-5042	3 Column Tray Assembly	2-5	0	0
	099-5044	4 Column Tray Assembly	0	2-5	0
	099-5046	5 Column Tray Assembly	0	0	2-5
4	099-5036	Mint Unit Final Assembly	1	1	1
5	099-8081	Column Letter Plate	1	1	1
6	224-8081	Price Card Sheet	1	2	2
7	2 1 O-5080	Cash Box Assembly	1	1	1
8	Coin Mechanism	Coinco No. C300-9404-977			
		Coinco No. C300-94140977			
		Coinco No. C300E9234			
		Coinco No. C300E9302L			
		Mars No. MC501 0			
		Mars No. TRC6010			
9	S2OC1032-6	Screw & Lockwasher No. 10-32x318	4	4	4
10	099-4064	Left Hand Support	1	1	1
11	099-4065	Right Hand Support	1	1	1
12	21 O-801 2	Plastic Canoe Clip .060 Round Head	18	18	24
13	21 O-8021	Plastic Canoe Clip .100 Round Head	12	12	12
14	220-4127	Track - Left Hand	6	6	6
15	220-4126	Center Track	0	0	6
16	220-4128	Track - Right Hand	6	6	6
17	203-4038	Support - Front Track	6	0	0
	240-4050	Support - Front Track	0	6	0
	224-4046	Support - Front Track	0	0	6
18	N20C832	Nut & Lockwasher No. 8-32	35-43	35-43	35-43
19	842C832-4	Screw No. 8-32x1 14	12-20	12-20	12-20
20	099-5018	Hinge Assembly	6-1 0	6-1 0	6-1 0
21	099-5024	Spring Holder Assembly "A"	3-5	0	0
	0995025	Spring Holder Assembly "B"	0	3-5	0
	099-5026	Spring Holder Assembly "C"	0	0	3-5
22	21 O-7000	Spring Guide	9-1 5	12-20	15-25
23	S42C832-4	Screw No. 8-32x1 14	26	26	26
24	099-5030	Main Harness Assembly	1	1	1
25	099-4051	Cable Channel Cover	1	1	1
26	099-4072	Plug Holder	14	14	14
27	099-8014	Panel Mounting End Caps	7	7	7
28	099-8005	Main Harness	1	1	1
29	099-4052	Ribbon Cable Channel	1	1	1
30	160-4093	Vent Cover	1	1	1
31	099-4118	Ribbon Cable Cover	1	1	1

Figure 6 - MACHINE FINAL ASSEMBLY

INDEX NO.	PART NO.	DESCRIPTION	QTY. PER ASSEMBLY MODEL NO.		
			A	B	C
32	099-8004	Wire Harness - Changer	1	1	1
33	099-4054	Changer Plug Bracket	1	1	1
34	099-8052	Changer Plugs Assembly with C300 Socket	O/I	O/I	O/I
None	099-5117	Changer Plugs & Bracket Assembly	O/I	O/I	O/I
35	S20C632-4	Screw & Lockwasher No. 6-32x1/4	6	6	6
36	230-5038	Coin Entrance Chute Assembly	1	1	1
37	R10K312	Retaining Ring 5/1 6	2	2	2
38	230-5027	Coin Return Arm Assembly	1	1	1
39	230-5035	Coin Mechanism Mounting Plate Assembly	1	1	1
40	230-5036	Coin Return Chute Assembly	1	1	1
41	230-5037	Chute & Cash Box Holder Assembly	1	1	1
42	21 O-7005	Spring Latch - Cash Box	1	1	1
43	150-8252	Bottom Hinge Bearing	1 or 2	1 or 2	1 or 2
44	230-4046	Support - Main Shelf	2	2	2
45	W10C312	Washer 5/1 6	1	1	1
46	21 O-5076	Stop Arm Assembly	1	1	1
47	S40C1016-6	Screw No. 1 O-I 6x3/8	2	2	2
48	W1 OC8	Washer No. 8	1	1	1
49	200-5070	Junction Box Assembly Complete - Fuse	1	1	1
50	S30C3118-12	Screw & Lockwasher No. 5/1 6-I 8x3/4	14	14	14
51	001-8007	Leveler	4	4	4
52	224-5054	Cabinet Leg Assembly	2	2	2
53	099-5080	Cabinet Weldment	1	0	0
	099-5081	Cabinet Weldment	0	1	0
	099-5082	Cabinet Weldment	0	0	1
54	N20C2520	Nut & Lockwasher No. 1/4-20	4	4	4
55	099-5004	Door Assembly "A"	1	0	0
	099-5005	Door Assembly "B"	0	1	0
	099-5006	Door Assembly "C"	0	0	1
56	S20C2520-8	Screw & Lockwasher No. 1/4-20x1 /2	2	2	2
57	150-5244	Door Support Roller Assembly	1	1	1
58	R1 OK250	Retaining Ring - 1/4	2	2	2
59	001-6120	Door Support Pin	1	1	1
60	150-8020	Door Support Roller	1	1	1
61	150-4270	Door Support Roller Bracket	1	1	1
62	N23C5013	Nut No. 1/2-13	1	1	1
63	R12K312	Retaining Ring 5/1 6	1	1	1
64	170-5028	Drive Cam & Lift Lever Assembly	1	1	1
65	170-6008	Spacer Bushing	1	1	1
66	N20C1024	Nut & Lockwasher No. 1 O-24	2	2	2
67	S26C1024-8	Carriage Bolt No. 10-24x1/2	2	2	2
68	170-8003	"T" Handle	1	1	1
69	170-4089	Washer - Double "D"	1	1	1
70	099-4083	Door Switch Bracket	1	1	1
71	099-8037	Door Switch	1	1	1
72	099-5093	24 Volt Power Harness	1	1	1
73	S39C620-4	Screw 6-20x1 /4	0/4	0/4	0/4
74	A-099-8066	1/2 Printed Circuit Board Support	0/1	0/1	0/1
75	099-4110	Socket Cover	O/I	O/I	O/I
76	099-8064	Changer Plug Assembly Less C300 Socket	O/I	O/I	0/1
None	099-5116	Changer Plug & Bracket Assembly	O/I	O/I	O/I

Figure 6 - MACHINE FINAL ASSEMBLY

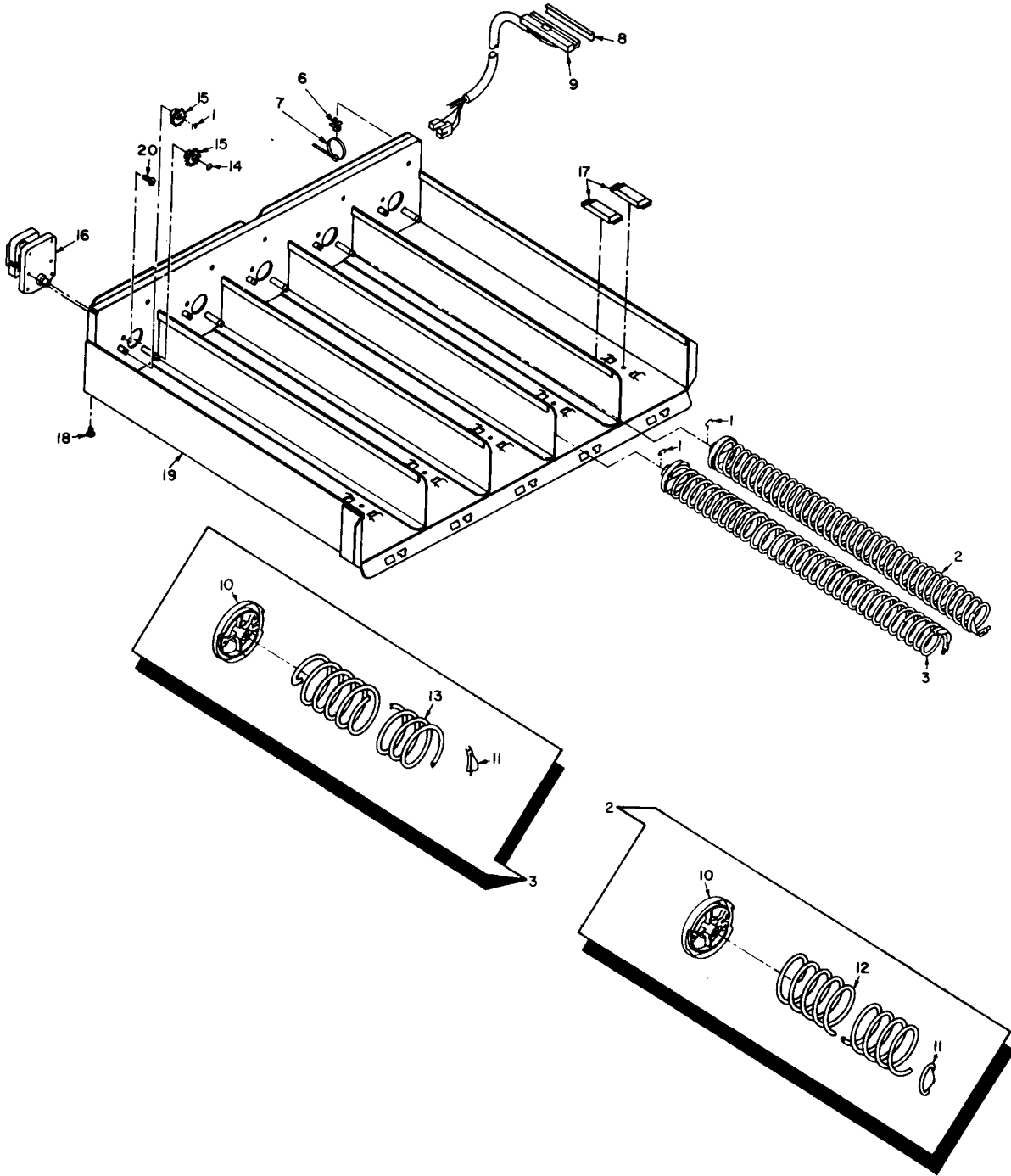

Figure 7 - TOP TRAY ASSEMBLY COMPLETE

INDEX NO.	PART NO.	DESCRIPTION	QTY. PER ASSEMBLY MODEL NO.		
			A	B	C
1	R10K312	Retaining Ring 5/1 6	9	12	15
2	21 O-51 25	Right Hand Spring Auger Assembly — 1 3/4" Pitch	3	4	5
3	210-5126	Left Hand Spring Auger Assembly — 1 13/4" Pitch	3	4	5
6	099-8062	Push Mount	1	1	1
7	001-8103	Ty Rap	1	1	1
8	099-8016	Strain Relief	1	1	1
9	099-5 120	Tray Wire Harness - 3 Column	1	0	0
	099-5121	Tray Wire Harness - 4 Column	0	1	0
	0995122	Tray Wire Harness - 5 Column	0	0	1
10	21 O-3006	Drive Gear - Helix	6	8	10
11	2 1 O-3020	Ejector	6	8	10
12	210-7011	Right Hand Spring Auger - 1 3/4" Pitch	3	4	5
13	21 O-701 2	Left Hand Spring Auger - 1 3/4" Pitch	3	4	5
14	210-8017	Pushnut	3	4	5
15	2 1 O-3005	Drive Gear	6	8	10
16	099-8017	Drive Motor	3	4	5
17	21 O-301 0	Wear Pad	6	8	10
18	21 O-8021	Canoe Clip .100 Round Head	2	2	3
19	099-5050	Main Tray Weldment - 3 Column Top	1	0	0
	099-5052	Main Tray Weldment - 4 Column Top	0	1	0
	099-5054	Main Tray Weldment - 5 Column Top	0	0	1
20	S41 C832-6	Screw No. 8-32x3/8	6	8	10

Figure 7 -TOP TRAY ASSEMBLY COMPLETE

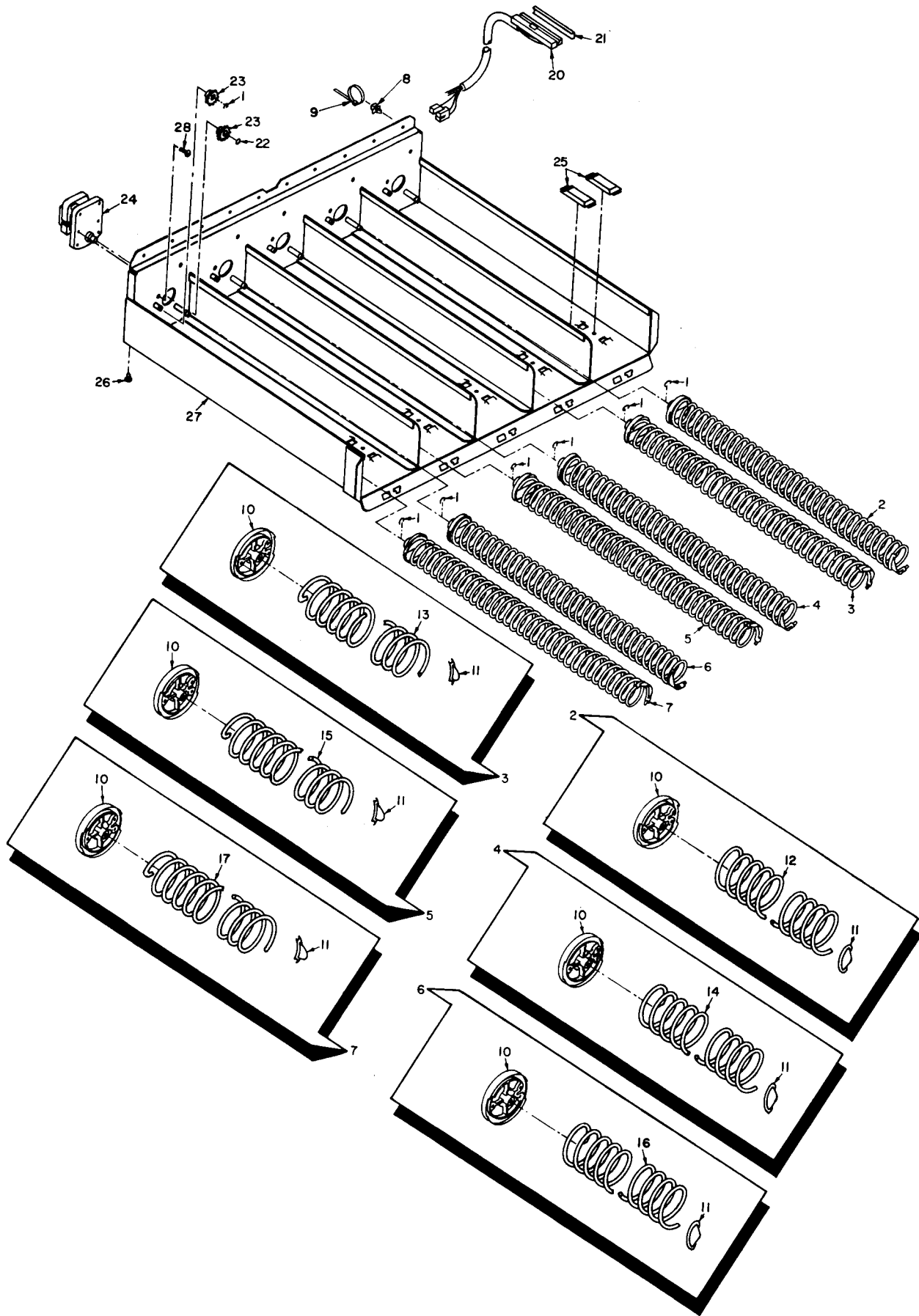

Figure 8 - WIDE COLUMN TRAY ASSEMBLY COMPLETE

INDEX NO.	PART NO.	DESCRIPTION	QTY. PER ASSEMBLY MODEL NO.		
			A	B	C
1	R10K312	Retaining Ring 5/16	9	12	15
2	210-5123	Right Hand Spring Auger Assembly — 1 1/2" Pitch	0-3	0-4	0-5
3	21 0-51 24	Left Hand Spring Auger Assembly — 1 1/2" Pitch	0-3	0-4	0-5
4	210-5125	Right Hand Spring Auger Assembly — 1 3/4" Pitch	0-3	0-4	0-5
5	21 0-51 26	Left Hand Spring Auger Assembly — 1 3/4" Pitch	0-3	0-4	0-5
6	21 0-51 27	Right Hand Spring Auger Assembly — 2" Pitch	0-3	0-4	0-5
7	21 0-5028	Left Hand Spring Auger Assembly — 2" Pitch	0-3	0-4	0-5
8	099-8062	Push Mount	1	1	1
9	001-8103	Ty Rap	1	1	1
10	21 0-3006	Drive Gear - Helix	6	8	10
11	21 0-3020	Ejector	6	8	10
12	21 0-701 5	Right Hand Spring Auger - 1 -1/2" Pitch	0-3	0-4	0-5
13	21 0-701 6	Left Hand Spring Auger - 1 -1/2" Pitch	0-3	0-4	0-5
14	21 0-701 1	Right Hand Spring Auger - 1 3/4" Pitch	0-3	0-4	0-5
15	21 0-701 2	Left Hand Spring Auger - 1 -3/4" Pitch	0-3	0-4	0-5
16	21 0-701 7	Right Hand Spring Auger - 2" Pitch	0-3	0-4	0-5
17	21 0-701 8	Left Hand Spring Auger - 2" Pitch	0-3	0-4	0-5
20	099-5120	Tray Wire Harness - 3 Column	1	0	0
	099-5121	Tray Wire Harness - 4 Column	0	1	0
	099-5122	Tray Wire Harness - 5 Column	1	0	1
21	099-8016	Strain Relief	3	41	51
22	210-8017	-Pushnut			
23	2 1 0-3005	Drive Gear	6	8	10
24	099-8017	Drive Motor	3	4	5
25	210-3010	Wear Pad	6	8	10
26	21 0-8021	Canoe Clip .100 Round Head	2	2	3
27	099-5051	Main Tray Weldment - 3 Column	1	0	0
	099-5053	Main Tray Weldment - 4 Column	0	1	0
	099-5055	Main Tray Weldment - 5 Column	0	0	1
28	S41 C832-6	Screw No. 8-32x3/8	6	8	10

Figure 8 WIDE COLUMN TRAY ASSEMBLY COMPLETE

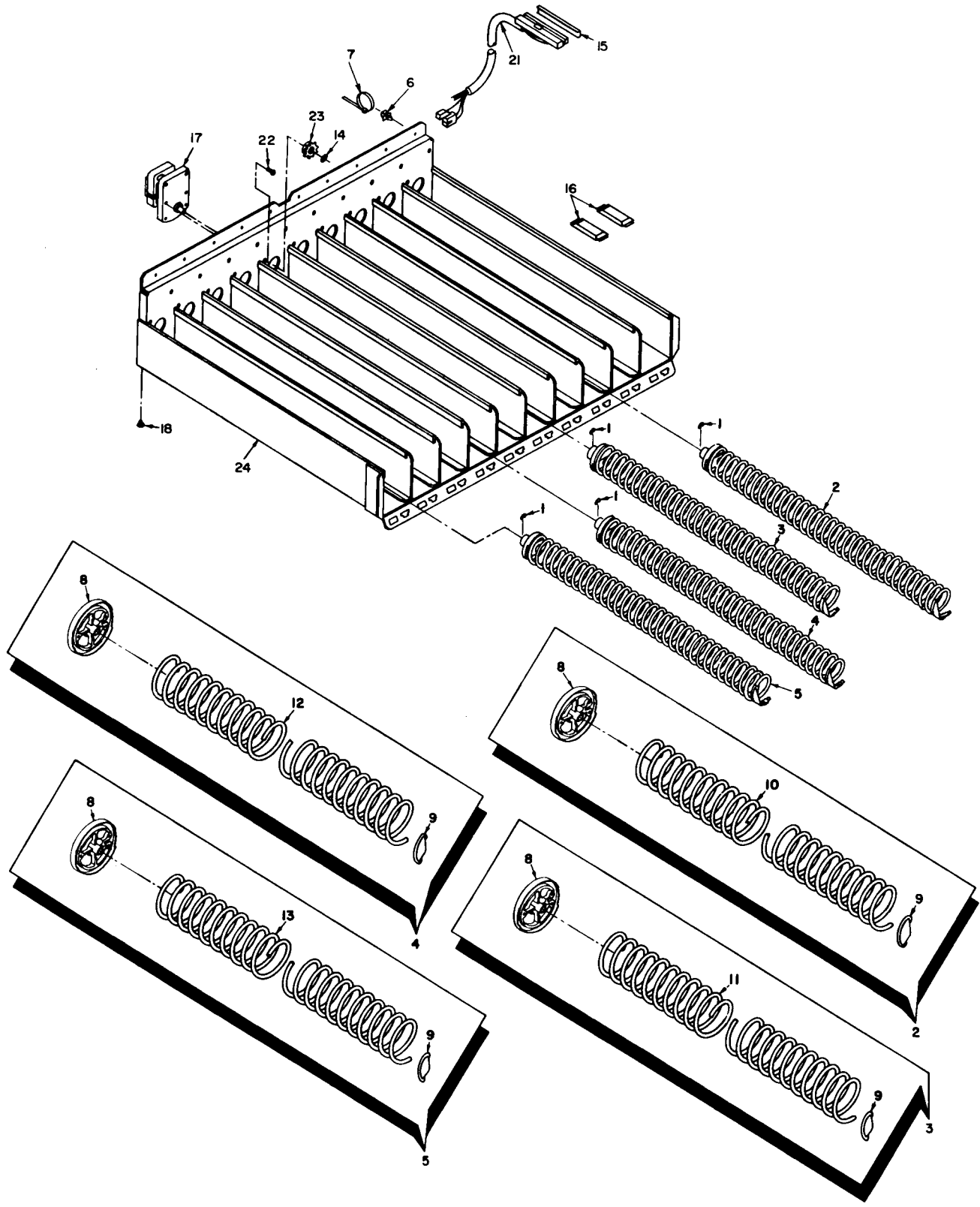

Figure 9 - NARROW COLUMN TRAY ASSEMBLY COMPLETE

INDEX NO.	PART NO.	DESCRIPTION	QTY. PER ASSEMBLY MODEL NO.		
			A	B	C
1	R10K312	Retaining Ring 5/1 6	6	8	10
2	2105120	Right Hand Spring Auger Assembly — 13/1 6" Pitch	1	1	1
3	210-5121	Right Hand Spring Auger Assembly — 1" Pitch	2	3	5
4	21 0-51 22	Right Hand Spring Auger Assembly - 1 3/16" Pitch	2	3	3
5	21 0-51 23	Right Hand Spring Auger Assembly — 1 1/2" Pitch	1	1	1
6	099-8062	Push Mount	1	1	1
7	001-8103	Ty Rap	1	1	1
8	21 0-3006	Drive Gear - Helix	6	8	10
9	21 0-3020	Ejector	6	8	10
10	210-7013	Right Hand Spring Auger - 13/1 6" Pitch	1	1	1
11	210-7010	Right Hand Spring Auger - 1" Pitch	2	3	5
12	21 0-701 4	Right Hand Spring Auger - 1 3/1 6" Pitch	2	3	3
13	21 0-701 5	Right Hand Spring Auger - 1 1/2" Pitch	1	1	1
14	21 0-801 7	Pushnut	6	8	10
15	099-8016	Strain Relief	1	1	1
16	21 0-301 0	Wear Pad	6	8	10
17	099-8017	Drive Motor	6	8	10
18	21 0-8021	Canoe Clip .100 Round Head	2	2	3
21	099-5123	Tray Wire Harness - 6 Column	1	0	0
	099-5124	Tray Wire Harness - 8 Column	0	1	0
	099-5125	Tray Wire Harness - 10 Column	0	0	1
22	S41 C832-6	Screw No. 8-32x3/8	12	16	20
23	21 0-3005	Drive Gear	6	8	10
24	099-5056	Tray Weldment - 6 Column	1	0	0
	099-5057	Tray Weldment - 8 Column	0	1	0
	099-5058	Tray Weldment - 10 Column	0	0	1

Figure 9 - NARROW COLUMN TRAY ASSEMBLY COMPLETE

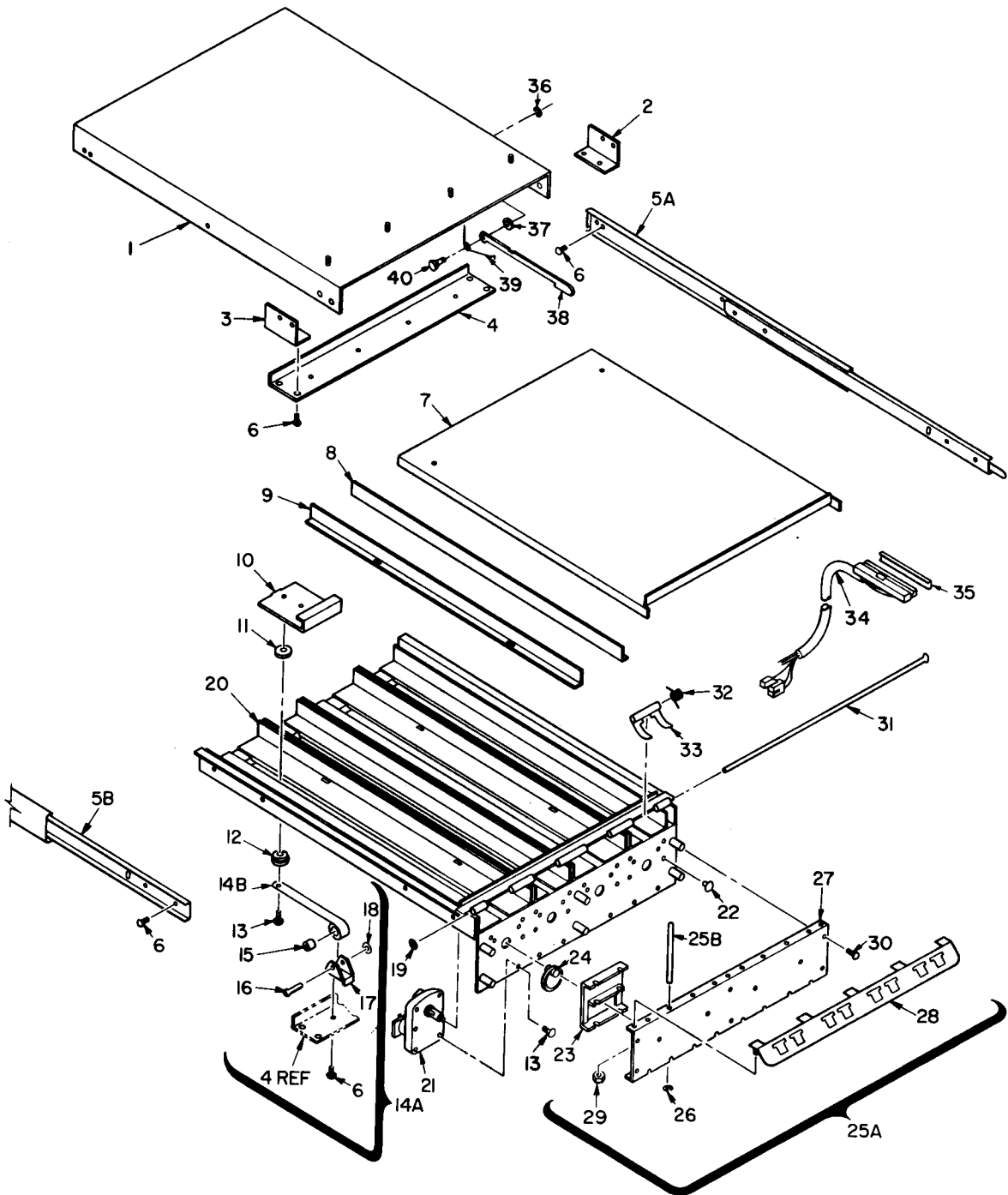

Figure 10 - MINT UNIT FINAL ASSEMBLY

INDEX NO.	PART NO.	DESCRIPTION	QTY. PER ASSEMBLY MODEL NO.		
			A	B	C
1	099-5031	Mint Mounting P.E.M. Assembly	1	1	1
2	099-4035	Left Hand Spring Holder	1	1	1
3	099-4036	Right Hand Spring Holder	1	1	1
4	099-4019	Spring Holder Bracket	1	1	1
5A	099-8032	Draw Slide With Latch	1	1	1
5B	099-8033	Draw Slide Without Latch	1	1	1
6	S42C832-4	Screw No. 8-32x1 /4	25	25	25
7	099-40 18	Gum & Mint Cover - 4 Column	1	1	1
8	099-4024	Adjustable Gum & Mint Divider (Left Hand)	2	2	2
9	099-4023	Adjustable Gum & Mint Divider (Right Hand)	2	2	2
10	099-4029	Gum &Mint Pusher	4	4	4
11	099-3004	Gum & Mint Pusher - Spacer	8	8	8
12	099-3003	Gum & Mint Pusher-Guide	8	8	8
13	S39C818-8	Screw No. 8-l 8x1/2	24	24	24
14A	099-5037	Gum & Mint Pusher Spring Assembly	4	4	4
14B	099-7000	Pusher Spring	1	1	1
15	099-3002	Gum & Mint Spring Roller	1	1	1
16	099-6000	Spring Roller Shaft	1	1	1
17	099-4020	Gum &Mint Spring Holder	1	1	1
18	099-8008	Pushnut .125 Stud	1	1	1
19	21 0-801 7	Pushnut .188 Stud	1	1	1
20	099-5020	Gum & Mint Tray - Weldment	1	1	1
21	099-8017	D.C. Drive Motor - Product Tray	4	4	4
22	21 0-8021	Canoe Clip .100 Round Head	16	16	16
23	099-4022	Gum & Mint Lifter	4	4	4
24	099-3001	Gum & Mint Delivery Cam	4	4	4
25A	099-5038	Front Panel Assembly	1	1	1
25B	099-6001	Gum & Mint Product Guide	8	8	8
26	R10K125	Retaining Ring 1/8	8	8	8
27	099-4028	Gum & Mint - 4 Column Front Panel	1	1	1
28	099-5022	Mint Price Holder Assembly	1	1	1
29	N20C832	Nut & Lockwasher No. 8-32	3	3	3
30	S 11 C832-4	Screw No. 8-32x1 /4	6	6	6
31	099-6004	Gum & Mint Gate Hinge Pin	1	1	1
32	150-7002	Torsion Spring	4	4	4
33	099-4021	Gum & Mint Gate	4	4	4
34	099-5121	4 Column Wiring Harness	1	1	1
35	099-8016	Strain Relief	1	1	1
36	R10K188	Retaining Ring 3/16	1	1	1
37	W10C8	Flat Washer No. 8	1	1	1
38	099-4129	Mint Latch	1	1	1
39	099-7003	Mint Latch Spring	1	1	1
40	099-6009	Mint Latch Pin	1	1	1

Figure 10 - MINT UNIT FINAL ASSEMBLY

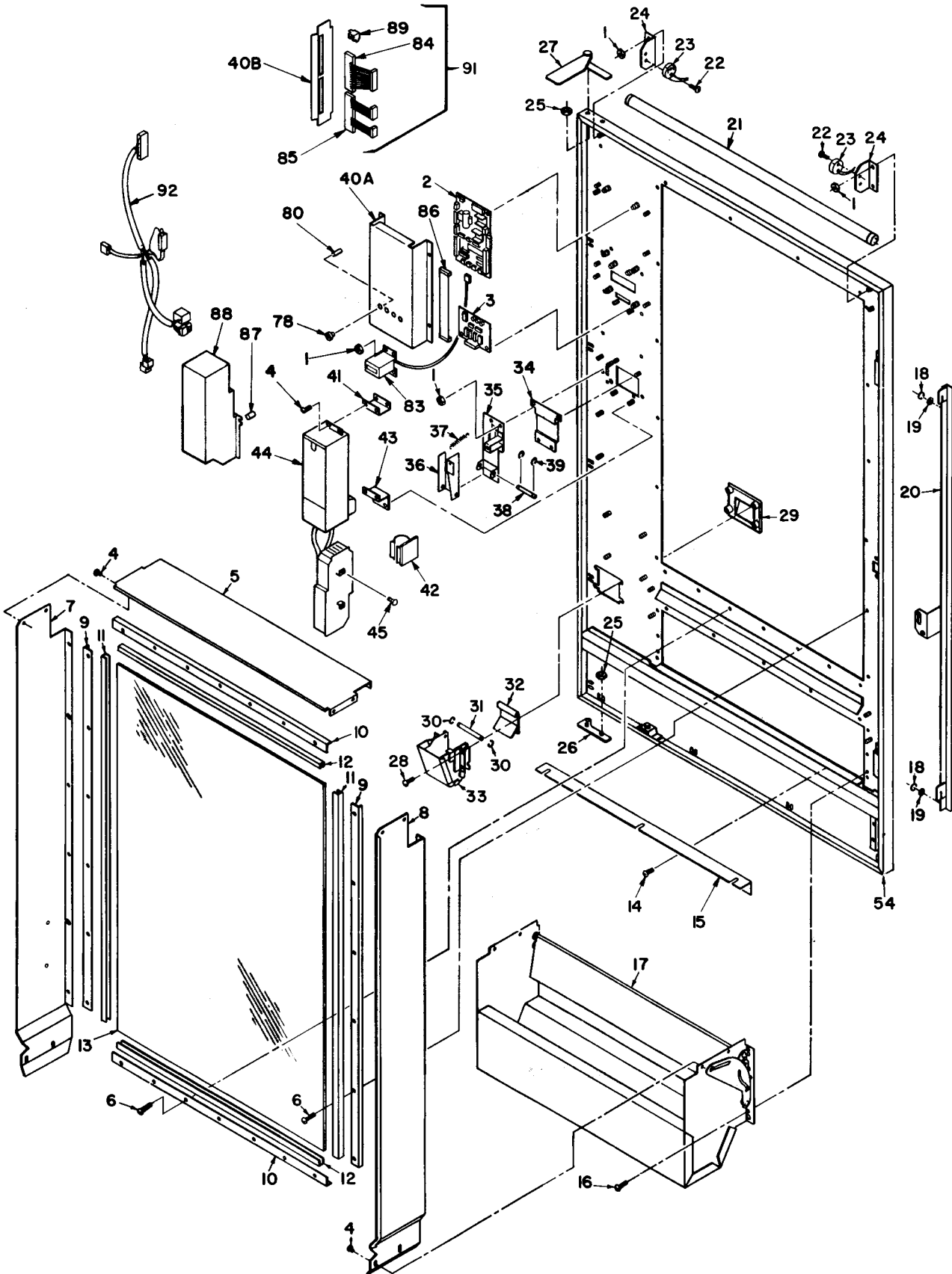

Figure 11 - DOOR ASSEMBLY

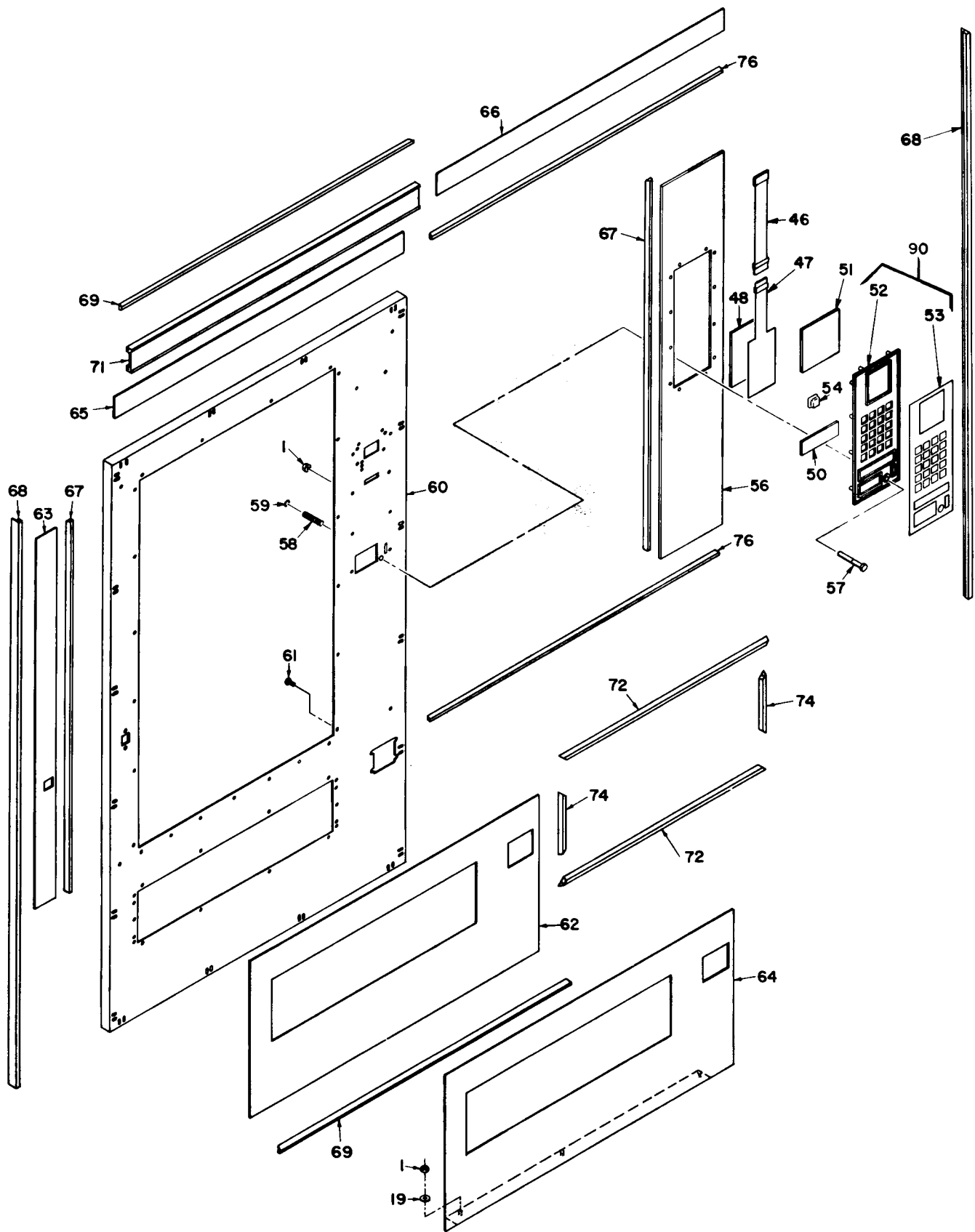

Figure 11 - DOOR ASSEMBLY

INDEX NO.	PART NO.	DESCRIPTION	QTY. PER ASSEMBLY MODEL NO.		
			A	B	C
1	N20C832	Nut & Lockwasher No. 8-32	11 or 15	15 or 19	15 or 19
2	099-8067	Controller Board	1	1	1
3	099-8068	Controller Display Board	1	1	1
4	S42C832-4	Screw No. 8-32x1/4	8 or 12	8 or 12	8 or 12
5	203-5024	Top Support - Product Guide "A"	1	0	0
	240-4024	Top Support - Product Guide "B"	0	1	0
	224-4022	Top Support - Product Guide "C"	0	0	1
6	S39C818-12	Screw No. 8-1 8x3/4	23	23	26
7	099-40 10	Left Hand Product Guide	1	1	1
8	099-4011	Right Hand Product Guide	1	1	1
9	099-4003	Glass Retainer-Left & Right Hand Sides	2	2	2
10	200-4027	Glass Retainer - Top & Bottom "A"	2	0	0
	240-4023	Glass Retainer-Top & Bottom "B"	0	2	0
	21 0-4052	Glass Retainer-Top & Bottom "C"	0	0	2
11	099-9012	Display Glass Gasket-Vertical	2	2	2
12	200-9007	Display Glass Gasket - Horizontal "A"	2	0	0
	099-9014	Display Glass Gasket - Horizontal "B"	0	2	0
	099-9013	Display Glass Gasket - Horizontal "C"	0	0	2
13	099-9007	Door Display Glass "A"	1	0	0
	099-9008	Door Display Glass "B"	0	1	0
	099-9009	Door Display Glass "C"	0	0	1
14	S40C818-6	Screw No. 8-18x3/8	3	4	4
15	200-4028	Support - Delivery Tray "A"	1	0	0
	240-4022	Support - Delivery Tray "B"	0	1	0
	230-4025	Support - Delivery Tray "C"	0	0	1
16	S39C818-6	Screw No. 8-1 8x3/8	20	20	21
17	099-5015	Delivery Tray "A" Assembly Complete	1	0	0
	099-5016	Delivery Tray "B" Assembly Complete	0	1	0
	099-5017	Delivery Tray "C" Assembly Complete	0	0	1
18	R10K187	Retaining Ring 3/16	2	2	2
19	W10C10	Flat Washer No. 10	2 or 5	2 or 5	2 or 5
20	230-5026	Lock Bar Assemble T-Handle	1	1	1
21	200-8000	Fluorescent Lamp - 14 Watt - F14T12-CW	1	0	0
	240-8000	Fluorescent Lamp - 20 Watt - F20T12-CW-26	0	1	0
	150-8023	Fluorescent Lamp - 25 Watt - F25T12-CW	0	0	1
22	S10C440-8	Screw No. 4-40x1/2	4	4	4
23	230-5028	Display Light Harness	1	1	1
24	220-4069	Light Bracket	0	2	2
25	N20C2520	Nut & Lockwasher No. 1/4-20	4	4	4
26	150-53 13	Bottom Door Hinge Assembly	1	1	1
27	150-53 16	Top Hinge Assembly	1	1	1
28	S20C1032-1/2	Screw & Lockwasher No. 10-32x1/2	4	4	4
29	00 I-2003	Coin Return Front	1	1	1
30	R10K125	Retaining Ring 1/8	2	2	2
31	001-6122	Pin - Coin Return Cup	1	1	1
32	001-2004	Coin Return Door	1	1	1

Figure 11 - DOOR ASSEMBLY

INDEX NO.	PART NO.	DESCRIPTION	QTY. PER ASSEMBLY MODEL NO.		
			A	B	C
33	001-5132	Coin Return Cup Assembly	1	1	1
34	099-4107	Validator Hole Cover	Oor1	Oor1	Oor 1
35	099-5011	Coin Chute & Bracket Assembly	1	1	1
36	099-4055	Coin Return Arm - Door	1	1	1
37	150-7003	Spring	1	1	1
38	230-6004	Coin Return Arm - Pin	1	1	1
39	R1 OK250	Retaining Ring 1/4	2	2	1
40A	099-4106	Electronic Cover	1	1	1
40B	099-4105	Electronic Cover - Side	1	1	1
41	099-40 13	Maka Bill Validator - Mounting Top	1	1	1
42	21 O-801 3	1" Wire Clamp	1	1	1
43	099-4 109	Maka Bill Validator - Mounting Bottom	1	1	1
44	099-8035	Maka Bill Validator	1	1	1
45	S40C1016-6	Screw No. 1 O-I 6x3/8	0 or 2	0 or 2	Oor2
46	099-8061	Key Pad Extension	1	1	1
47	099-8069	Key Pad	1	1	1
48	099-4108	Touch Pad Backing	1	1	1
50	099-9011	Instruction Glass	1	1	1
51	099-9016	Information Glass	1	1	1
52	099-2002	Bezel Plate	2	2	2
53	099-8042	Label-Bezel Casting	2	2	2
54	099-3000	Push Button	20	20	20
56	099-4017	Door Panel - Right Hand	1	1	1
57	099-6010	Coin Return Pin Assembly	1	1	1
58	001-7019	Coin Return Spring	1	1	1
59	R10K312	Retaining Ring 5116	1	1	1
60	099-5127	Door Weldment "A"	1	0	0
	099-5128	Door Weldment "B"	0	1	0
	099-5129	Door Weldment "C"	0	0	1
61	S40C620-6	Screw No. 6-20x3/8	16-24	16-24	16-24
62	099-4079	Door Panel - Bottom "A"	Oor 1	0	0
	240-4020	Door Panel - Bottom "B"	0	Oor1	0
	230-4030	Door Panel - Bottom "C"	0	0	Oor1
63	21 O-41 28	Door Panel Left Hand T-Handle	1	1	1
64	099-5039	Door Panel - Bottom Rowe "A"	Oor1	0	0
	240-5018	Door Panel - Bottom Rowe "B"	0	Oor 1	0
	230-5048	Door Panel - Bottom Rowe "C"	0	0	Oor1
65	099-408 1	Door Top Panel "A"	Oor1	0	0
	241-4018	Door Top Panel "B"	0	Oor 1	0
	21 o-41 20	Door Top Panel "C"	0	0	Oor 1
66	099-4082	Door Panel - Rowe Top "A"	Oor 1	0	0
	240-4000	Door Panel - Rowe Top "B"	0	Oor 1	0
	220-4101	Door Panel - Rowe Top "C"	0	0	Oor1
67	21 O-2004	Door Extrusion Right & Left Hand Vertical	2	2	2
68	150-2022	Door Frame Sides	2	2	2

Figure 11 - DOOR ASSEMBLY

INDEX NO.	PART NO.	DESCRIPTION	QTY. PER ASSEMBLY MODEL NO.		
			A	B	C
69	200-2007	Door Frame Ends "A"	Oor2	0	0
	240-2000	Door Frame Ends "B"	0	Oor2	0
	150-2021	Door Frame Ends "C"	0	0	Oor2
71	200-2019	Door Frame Top - Rowe "A"	Oor1	0	0
	240-2009	Door Frame Top - Rowe "B"	0	Oor1	0
	160-2040	Door Frame Top - Rowe "C"	0	0	Oor 1
72	200-2005	Delivery Tray Extrusion Top & Bottom "A"	2	0	0
	240-2003	Delivery Tray Extrusion Top & Bottom "B"	0	2	0
	21 O-2005	Delivery Tray Extrusion Top & Bottom "C"	0	0	2
74	220-2005	Delivery Tray Extrusion Right & Left Hand Sides	2	2	2
76	200-2008	Door Extrusion Top & Bottom Horizontal "A"	2	0	0
	240-2001	Door Extrusion Top & Bottom Horizontal "B"	0	2	0
	170-2002	Door Extrusion Top & Bottom Horizontal "C"	0	0	2
80	099-8028	Plunger	4	4	4
78	099-8029	Plunger Holder	4	4	4
83	099-8065	Cash Counter Assembly	1	1	1
84	099-5 113	Jumper - Changer Harness	1	1	1
85	099-5114	Jumper Tray Harness	1	1	1
86	099-8063	Controller to Display Harness	1	1	1
87	099-8073	1/2" Spacer Mars Kit	4	4	4
88	099-8070	Mars - Bill Validator	O/I	O/I	O/I
89	099-8014	Panel Mounting End Caps	2	2	2
90	099-5094	Coin Entrance Plate Assembly	1	1	1
91	099-5 142	Jumper Mounting Assembly	1	1	1
92	099-5126	Bill Validator Harness II	1	1	1

NOTE: For Door Panels or Door Trim Parts
Give Part Number Listed, Styling and Color.

Figure 11 - DOOR ASSEMBLY

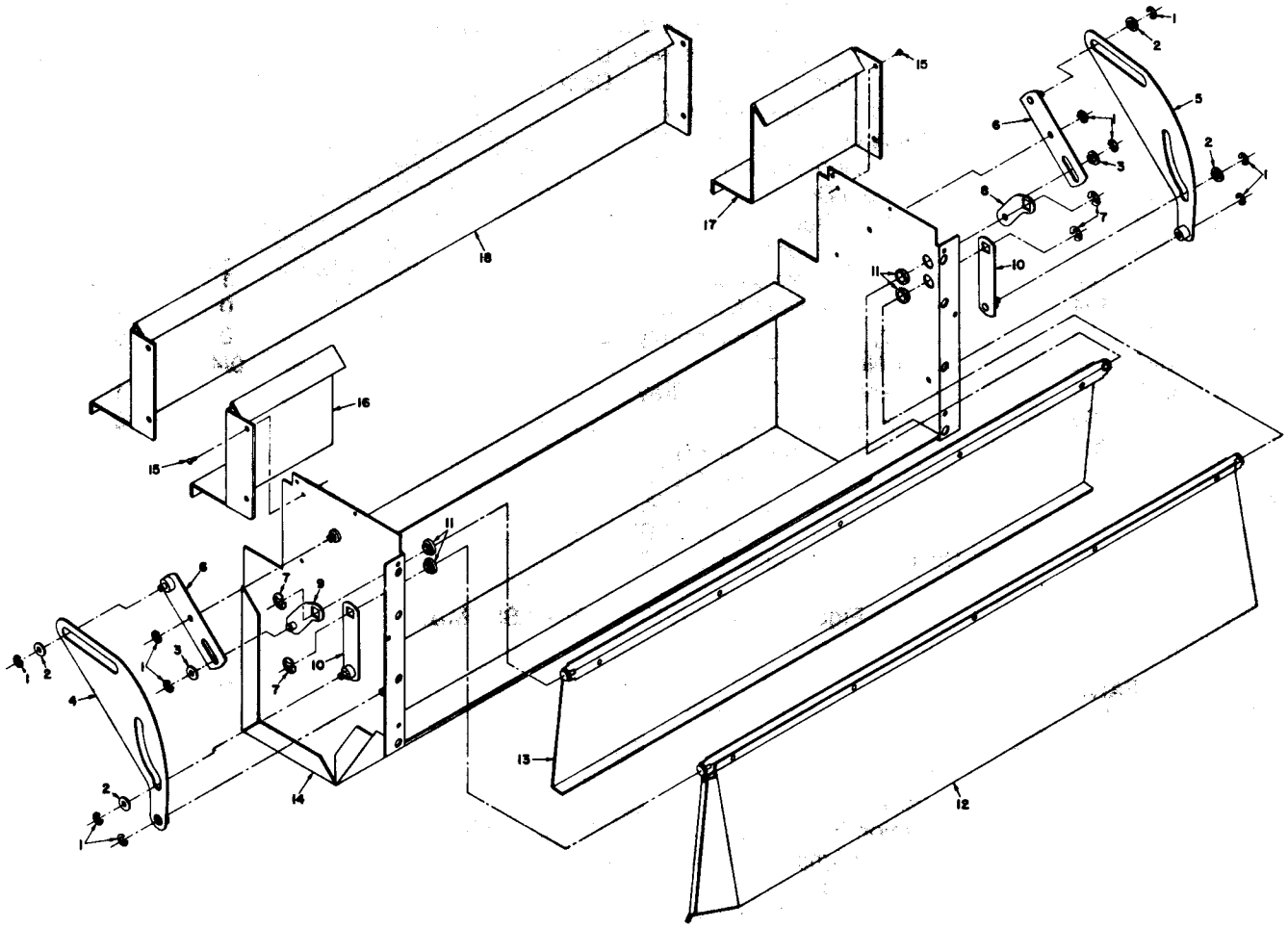

Figure 12 - DELIVERY TRAY ASSEMBLY

INDEX NO.	PART NO.	DESCRIPTION	QTY. PER ASSEMBLY		
			MODEL NO.		
			A	B	C
1	R 1 OK250	Retaining Ring 1/4	10	10	10
2	220-6020	Roller - Drive & Lift Arm	4	4	4
3	220-602 1	Roller - Lift Arm	2	2	2
4	220-5121	Left Hand Idler Arm Assembly	1	1	1
5	220-5120	Right Hand Idler Arm Assembly	1	1	1
6	220-5119	Lift Arm Assembly-Anti-Cheat	2	2	2
7	R1 OK375	Retaining Ring 3/8	4	4	4
8	220-5116	Right Hand Drive Arm Assembly - Anti-Cheat Door	1	1	1
9	220-5117	Left Hand Drive Arm Assembly Anti-Cheat Door	1	1	1
10	2205118	Drive Arm Assembly - Delivery Door	2	2	2
11	220-6022	Bushing Delivery & Anti-Cheat Door	4	4	4
12	200-5068	Delivery Door Assembly "A"	1	0	0
	240-5023	Delivery Door Assembly "B"	0	1	0
	220-5 114	Delivery Door Assembly "C"	0	0	1
13	099-5 109	Anti-Cheat Door Assembly "A"	1	0	0
	099-5 110	Anti-Cheat Door Assemble "B"	0	1	0
	099-5111	Anti-Cheat Door Assembly "C"	0	0	1
14	099-5130	Delivery Tray Weld Assembly "A"	1	0	0
	099-5131	Delivery Tray Weld Assembly "B"	0	1	0
	099-5132	Delivery Tray Weld Assembly "C"	0	0	1
15	S42C832-4	Screw No. 8-32x1/4	0/4	4	4
16	099-4091	Left Hand Back Delivery Tray	0	1	0
	099-4093	Left Hand Back Delivery Tray	0	0	1
17	099-4090	Right Hand Back Delivery Tray	0	1	0
	099-4092	Right Hand Back Delivery Tray	0	0	1
18	099-5147	No. Mint Cover Assembly "A"	1	0	0
	099-5148	No. Mint Cover Assembly "B"	0	1	0
	099-5149	No. Mint Cover Assembly "C"	0	0	1

Figure 12 - DELIVERY TRAY ASSEMBLY

INDEX NO.	PART NO.	DESCRIPTION	QTY. PER ASSEMBLY		
			MODEL NO.		
			A	B	C
1	001-8101	Starter FS25		1	
2	S42C832-4	Screw No. 8-32x1/4		2	
3	200-4091	Junction Box Back		1	
4	200-8031	Fuse 3.2 Amp		2	
5	001-8071	Fuse Holder		2	
6	2 1 O-8003	Cap Housing (2 Circuit)		1	
7	21 O-8005	Cap Housing (6 Circuit)		1	
8	S10C440-6	Screw No. 4-40x3/8		2	
9	001-8028	Starter Socket		1	
10	N20C832	Nut & Lockwasher No. 8-32		6	
11	W1 OC8	Washer No. 8		6	
12	400-8046	Ballast - 22 Watt		1	
13	200-8011	Transformer		1	
14	00 I-8020	Rubber Grommet 3/8		1	
15	001-8081	Strain Relief		2	
16	160-4099	Power Cord Plate		1	
17	00 I-8080	Power Cord		1	
18	200-5071	Junction Box Weldment		1	

Figure 13 -JUNCTION BOX ASSEMBLY

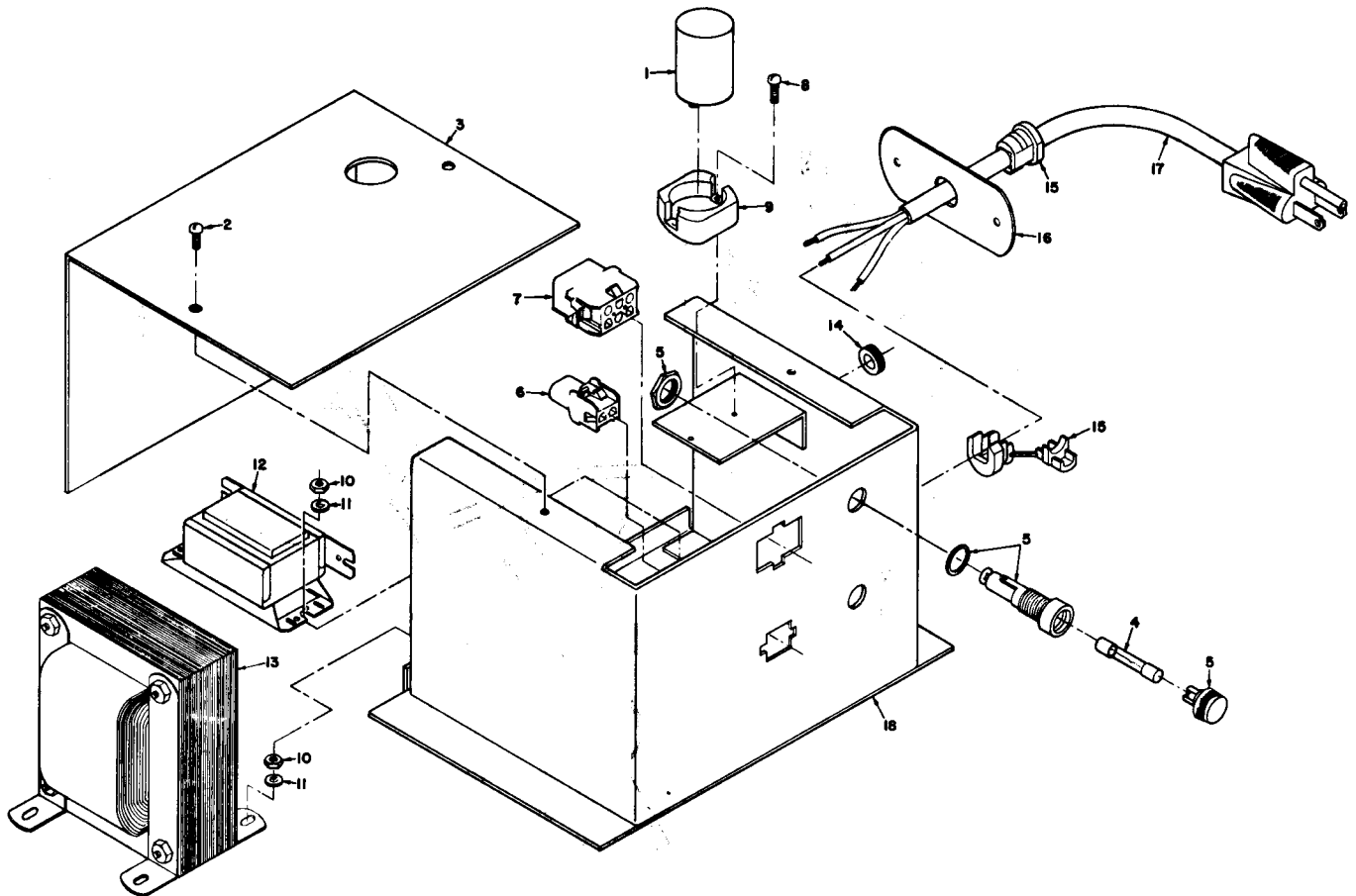

Figure 13 - JUNCTION BOX ASSEMBLY

CHANGES

LEKTRO-VEND CORP., AURORA, ILL

A-099-5096

CHG. A

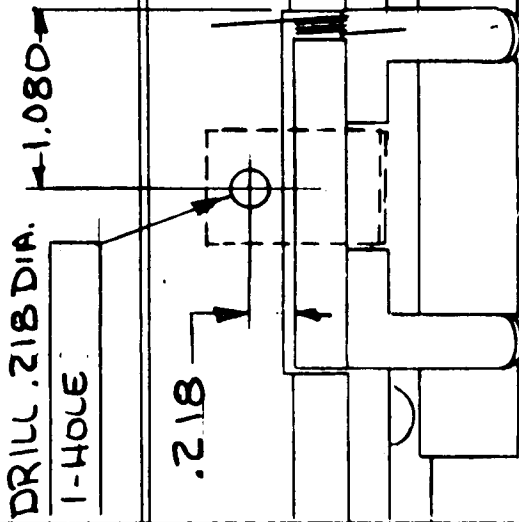

REQ.	PART NO.	QUAN. PER.	NEXT ASSEM.
1	A-099-5095		
1	A-400-8028		
1	W10C8		

NOTES.
 1. DRILL HOLE AS SHOWN ABOVE
 2. MOUNT RETAINER UNDER EJECOR AS SHOWN BY DOTTED LINES SO THAT ONLY (1) ONE ITEM WILL VEND AT A TIME.

READ ALL NOTES BEFORE STARTING WORK

OPER.	DEPT.	DESCRIPTION	TOOL NO.	DRAWN	DATE	MATERIAL	FINISH	SCALE	DO NOT SCALE PRINT
1	55	ASSEMBLE		T.G.K.	10-21-87				
2	55	PACK AND SHIP WITH COPY OF THIS SHEET		CHECKED					
				APPROVED					DO NOT SCALE PRINT
									TOLEANCES UNLESS OTHERWISE SPECIFIED
									FRACT. DECIMALS ANGLES
									PART NAME
					MAR 20 1989				SMALL MINT RETAINER KIT
					55 56 G				PCS PER FT.
									SHEET SIZE X
									A-099-5096